



EN 14975



LMF 60

- DE FEUERHEMMENDE BODENTREPPPE
- EE TULEKINDEL TREPP
- ES ESCALERA ESCAMOTEABLE IGNÍFUGA
- FI PALONKESTÄVÄ PORRAS
- FR ESCALIER ESCAMOTABLE COUPE-FEU
- GB FIRE-RESISTANT LOFT LADDER
- HU TŰZÁLLÓ PADLÁSFELJÁRÓ LÉPCSŐ
- IT LE SCALE PER LA SOFFITTA

- LT UGNIAI ATSPARŪS PALĒPĒS LAIPTAI
- LV UGUNSDROŠAS BĒNIŅU KĀPNES
- NL BRANDWERENDE ZOLDERTRAP
- PL SCHODY STRYCHOWE OGNIODPORNE
- PT ESCADA DE SOTAO-ENCAIXADA
- RO SCĂRI DE ACCES LA POD REZISTENTE LA FOC
- RU ЧЕРДАЧНАЯ ЛЕСТНИЦА СОПНЕСТОЙКИМ ЛЮКОМ
- SK STROPNÉ PROTIPOŽIARNE SKLÁPACIE SCHODY
- US FIRE-RESISTANT ATTIC LADDER

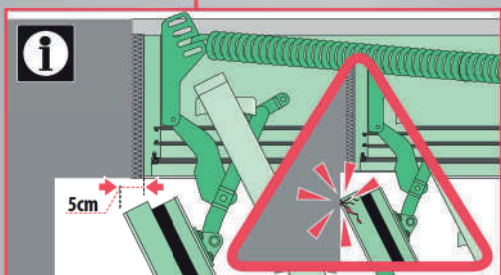
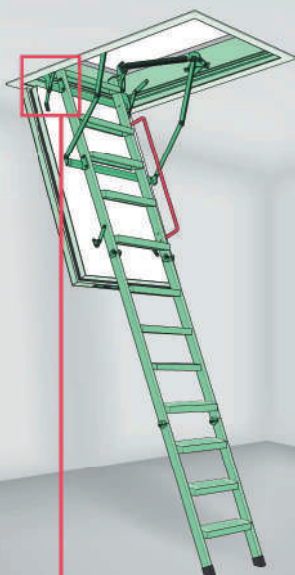
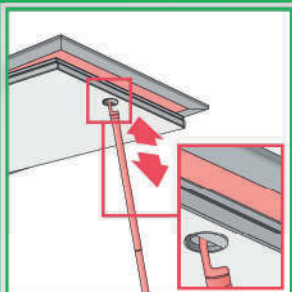

<http://www.fakro.com/download/film-installation-instructions/loft-ladders/>

READ SAFETY INSTRUCTION BEFORE USING



NC 9CE



WARNING!

- CZ** Montáž schodů a jejich použití je nutno provádět v souladu s montážním návodem a návodem k použití. Bezpečnost použití závisí na provedení všech činností uvedených v montážním návodu a na použití schodů v souladu se všemi body uvedenými v návodu k použití. POZOR! Použití schodů v rozporu s návodem je zakázáno, může způsobit vážnou nehodu a má za následek ztrátu záruky a odpovědnosti výrobce.
- DE** Die Bedienungssicherheit hängt davon ab, ob alle in der Montageanleitung genannten Tätigkeiten ausgeführt wurden und die Treppe nach allen in der Bedienungsanleitung angeführten Punkten benutzt wird. ACHTUNG! Die Nichtbeachtung der Anleitung ist verboten und kann schwere Unfälle verursachen und ist aus der Garantie ausgeschlossen. Der Hersteller übernimmt keine Verantwortung.
- EE** Pööninguluugi paigaldamine ja kasutamine peab toimuma vastavalt paigaldusjuhistele ja kasutusjuhendile. Kasutusohutus sõltub paigaldamisjuhistes näidatud kõigi toimingute rakendamisest ja pööninguluugi kasutamisest vastavalt kõikidele kasutusjuhendis toodud punktidele. TÄHELEPANU! Juhistele mitte vastav kasutamine on rangelt keelatud kuna võib põhjustada tõsise õnnetuse, see tühistab garantii ning muudab Tootja toote eest enam mitte vastutavaks.
- ES** El montaje y el uso de la escalera debe llevarse a cabo de acuerdo con el manual de instalación y el manual de uso de la misma. La seguridad de uso de la escalera depende de la correcta realización de todas las acciones indicadas en el manual de instalación y uso de la escalera de acuerdo con todos los puntos indicados en el manual de uso. ¡PRECAUCIÓN! Está prohibida la utilización de la escalera que no sea conforme con el manual de instrucciones, porque puede causar un accidente grave, deshabilita la garantía y hace que el fabricante no se responsabilice.
- FI** Ullakkoportaiden asennus ja käyttö on suoritettava asennusohjeiden ja käyttöohjeiden mukaisesti. Ullakkoportaiden turvallinen käyttö edellyttää, että asennusohjeissa näytetyt toimenpiteet on tehty ja ullakkoportaita käytetään käyttöohjeita noudattaen. VAROITUS! Jos ullakkoportista käytetään ohjeiden vastaisesti, saattaa se aiheuttaa vakavan onnettomuuden.
- FR** Le montage et l'utilisation de l'escalier doivent être réalisés dans le respect de l'instruction de montage et d'utilisation. La sécurité d'utilisation dépend de la réalisation de toutes les activités indiquées dans l'instruction de montage et d'utilisation de l'escalier. ATTENTION! L'utilisation des escaliers contrairement à l'instruction est interdite, elle peut provoquer un accident grave, annulation de la garantie et manque de responsabilité du fabricant.
- GB** Installation and operation of the loft ladder must be carried out in compliance with the fitting instructions and user manual. Safety of use depends on the implementation of all actions shown in the fitting instructions and use of the loft ladder in accordance with all points shown in the user manual. CAUTION! Using the loft ladder in violation of the instructions is strictly forbidden, may result in a serious injury, will invalidate the Warranty and makes the Manufacturer no longer liable for the product.
- HU** A padlásfeljáró lépcső beépítését és üzemeltetését a beépítési- és használati útmutatóban foglaltak szerint kell elvégezni! Az üzemeltetés biztonságáért függ a beépítési útmutatóban feltüntetett valamennyi művelet elvégzésétől valamint a használati útmutató valamennyi pontjának betartásától. FIGYELEM! A padlásfeljáró lépcső útmutatóval ellentétben vagy azzal nem megegyező módon történő használata tilos és balesetveszélyes, illetve súlyos balesettel járhat valamint garanciavesztést eredményez; a fentiekből adódó következményekért a gyártó nem vállal semmiféle felelősséget.
- IT** L'installazione e l'uso della scala devono essere eseguiti in conformità alle istruzioni di montaggio e le istruzioni d'uso. La sicurezza d'uso dipende dalla realizzazione di tutte le attività indicate nelle istruzioni di montaggio e dall'uso della scala in conformità a tutti i punti indicati nelle istruzioni d'uso. ATTENZIONE! È assolutamente vietato l'utilizzo difforme alle istruzioni d'uso dato che può essere causa di gravi incidenti ed in ogni caso fa decadere la garanzia nonché qualsiasi responsabilità del produttore.
- LT** Palėpės laiptų montavimas ir eksploatavimas turi būti atliekamas pagal montavimo ir naudojimo instrukciją. Naudojimo saugumas priklauso nuo visų veiksmų, nurodytų montavimo instrukcijoje, įgyvendinimo, ir palėpės kopėčių naudojimo, vadovaujantis visais vartotojo vadove nurodytais nurodymais. ĮSPĖJIMAS: naudotis palėpės laiptais pažeidžiant instrukcijos griedžiai draudžiama, nes tai gali sukelti rimtą nelaimingą atsitikimą, ir gamintojas turi teisę panaikinti garantiją ir nebeatsakyti už gaminį.
- LV** Bēniņu kāpņu uzstādīšana un lietošana veicama atbilstoši montāžas instrukcijai un lietotāja rokasgrāmatai. Droša lietošana ir atkarīga no tā, vai precīzi ievērotas visas uzstādīšanas instrukcijas un kāpnes tiek lietotas atbilstoši visiem lietotāja rokasgrāmatā norādītajiem punktiem. UZMANĪBU! Kāpņu lietošana neatbilstoši instrukcijas prasībām ir stingri aizliegta, jo tā var izraisīt nopietnus nelaimes gadījumus, kā arī pārtrauc noteikto garantijas apkalpošanu un ražotāja atbildību par produktu.
- NL** Voer de montage en het gebruik van de trap uit in overeenstemming met de montagehandleiding en de gebruiksaanwijzing. De gebruiksviligheid is afhankelijk van de uitvoering van alle handelingen uit de montagehandleiding en het gebruik van de trap in overeenstemming met alle punten uit de gebruiksaanwijzing.. LET OP! Gebruik van de zoldertrap is niet toegestaan wanneer deze niet conform de handleiding is gemonteerd. Dit kan gevaarlijke situaties veroorzaken. De garantie wordt in dit geval niet toegekend en de producent is niet verantwoordelijk voor de mogelijke gevolgen.
- PL** Montaż i użytkowanie schodów należy wykonywać zgodnie z instrukcją montażu i instrukcją użytkowania. Bezpieczeństwo użytkowania zależy od wykonania wszystkich czynności wskazanych w instrukcji montażu oraz korzystania ze schodów zgodnie ze wszystkimi punktami wskazanymi w instrukcji użytkowania. UWAGA! użytkowanie schodów niezgodnie z instrukcją jest zabronione, może spowodować groźny wypadek, wyłącza gwarancję oraz powoduje brak odpowiedzialności producenta.
- PT** A montagem e utilização das escadas devem ser realizadas de acordo com as instruções de montagem e instruções de utilização. A segurança na utilização depende da execução de todas as ações indicadas nas instruções de montagem e de uma utilização das escadas de acordo com todos os pontos indicados nas instruções de utilização. ATENÇÃO! O uso da escada violando as instruções é estritamente proibido, pois isso pode causar um acidente grave, anula a Garantia e torna o Fabricante não responsável pelo produto
- RO** Instalarea și utilizarea scării trebuie efectuate conform instrucțiunilor de montaj și manualului de utilizare. Siguranța utilizării depinde de punerea în practică a tuturor acțiunilor prezentate în instrucțiunile de montaj și de folosirea scării în conformitate cu toate punctele prezentate în manualul de utilizare. ATENȚIE! Încălcarea acestor instrucțiuni este interzisă deoarece duce la pierderea garanției și poate provoca accidente grave. Producătorul nu își asumă răspunderea pentru evenimentele produse ca urmare a încălcării instrucțiunilor de instalare și utilizare a scării.
- RU** Монтаж и эксплуатация лестницы должны проводиться согласно инструкциям по монтажу и эксплуатации. Безопасность эксплуатации зависит от выполнения всех правил, представленных в инструкции по монтажу и в инструкции по эксплуатации. ВНИМАНИЕ! Неправильная эксплуатация лестницы может привести к несчастному случаю, отменить гарантию производителя и снять с него ответственность.
- SI** Montažo uporaba stopnic je potrebno izvajati v skladu z navodili za montažo oziroma v navodili za uporabo. Varnost uporabe je odvisna od izvedbe vseh postopkov naštetih v navodilih za montažo oziroma od uporabe stopnic v skladu z vsemi točkami zapisanimi v navodilih za uporabo. OPOZORILO! Uporaba lestve podvozja v nasprotju z navodili je strogo prepovedana, saj lahko povzroči resno nesrečo, razveljavi garancijo in povzroči, da proizvajalec ne odgovarja več za izdelek.
- SK** Montáž schodov a ich použitie je nutné prevádzkať v súlade s montážnym návodom a návodom na použitie. Bezpečnosť použitia závisí na prevedení všetkých činností uvedených v montážnom návode a návode na použitie schodov v súlade so všetkými bodmi uvedenými v tomto návode. POZOR! Používanie schodov v rozpore s návodom je zakázané, môže spôsobiť vážnu nehodu a má za následok stratu záruky a zodpovednosti výrobcu.
- US** Installation and operation of the attic ladder must be carried out in compliance with the fitting instructions and user manual. Safety of use depends on the implementation of all actions shown in the fitting instructions and use of the attic ladder in accordance with all points shown in the user manual. WARNING! Using the attic ladder in violation of the instructions is strictly forbidden as it may cause a serious accident, it voids the Warranty and makes the Manufacturer no longer liable for the product.

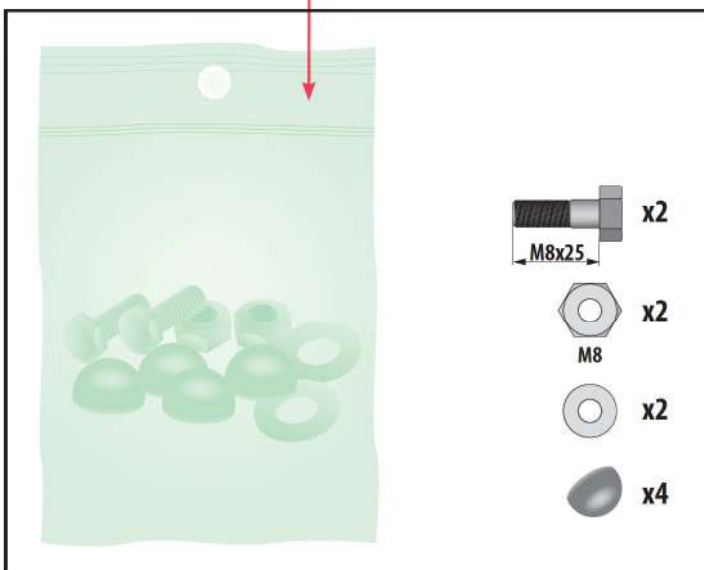
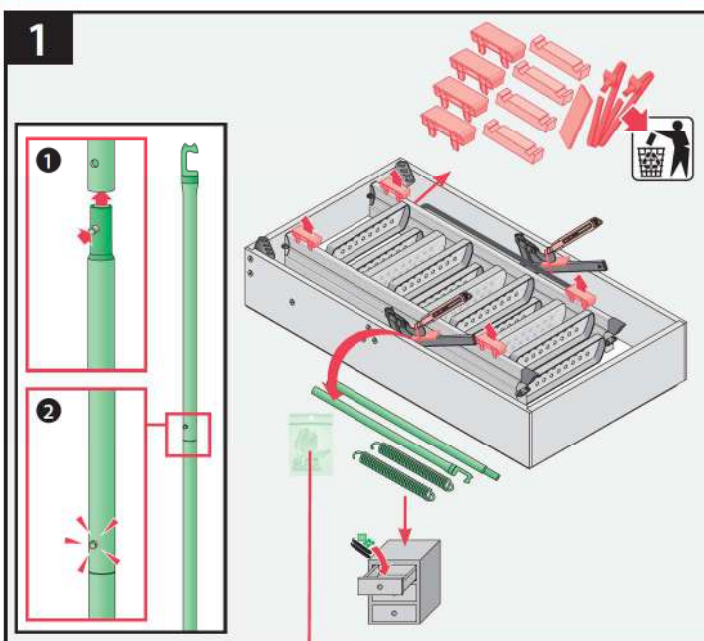
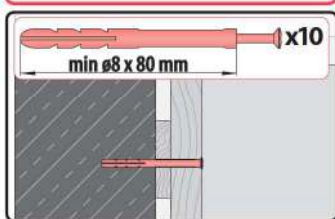
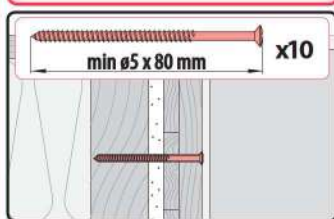
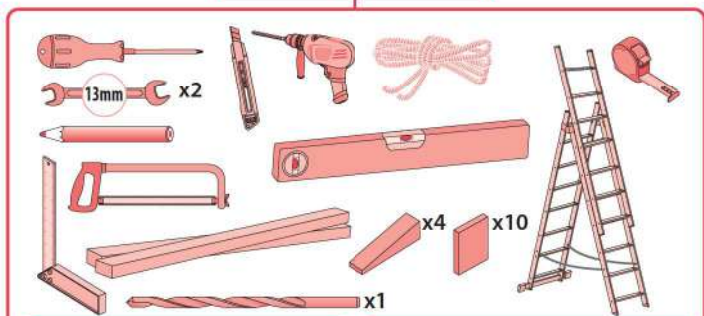

2

H	H _{min}
280 cm	233 cm
305 cm	234 cm

LMF60 ■■■ cm**A x B** cm

NR. ART.

info: www.fakro.com

■ - ■ kg W = ■ cm

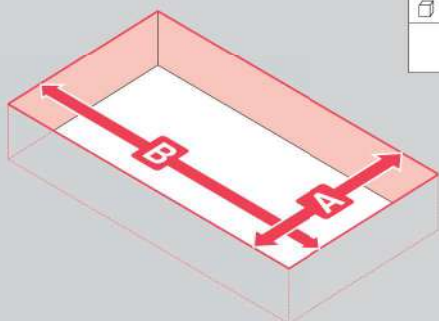
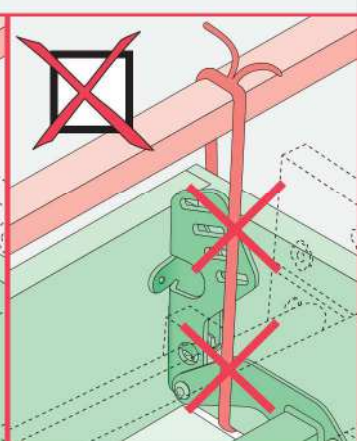
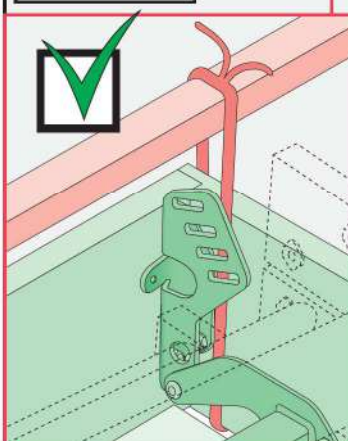
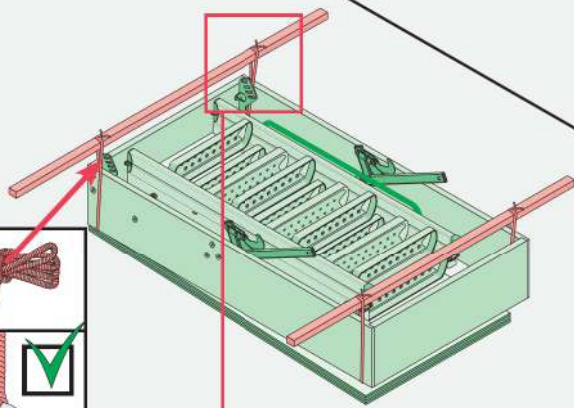
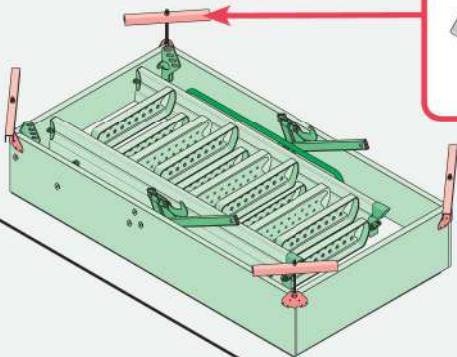
□ - ■ m³ L = ■ cm**3****LXK****4**

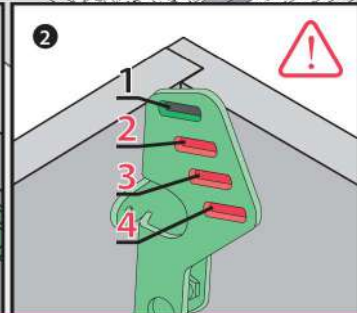
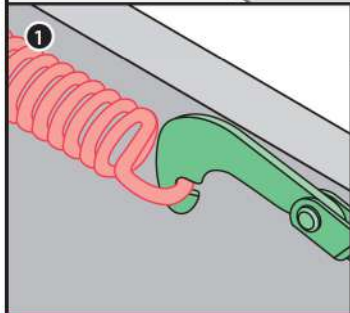
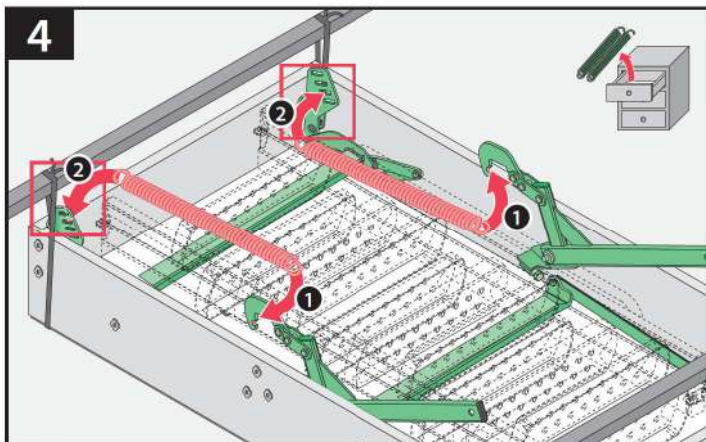

LMF60 cm
A x B cm

A x B / H cm
70 x 140 / 280 cm

LMF60 cm
A x B cm

A x B / H cm
70 x 130 / 280 cm
86 x 130 / 280 cm
70 x 130 / 305 cm
70 x 140 / 305 cm
86 x 130 / 305 cm

LMF60 cm
A x B cm

A x B / H cm
60 x 120 / 280 cm
70 x 120 / 280 cm

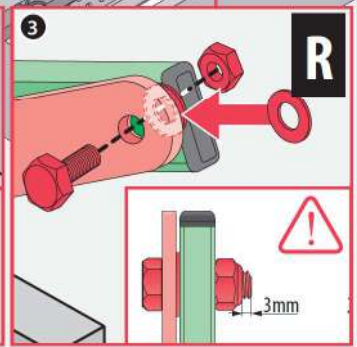
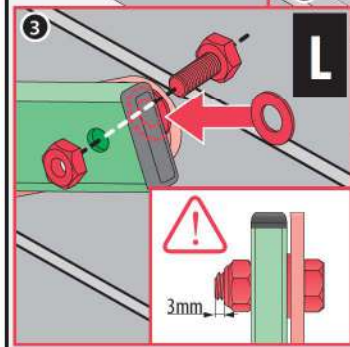
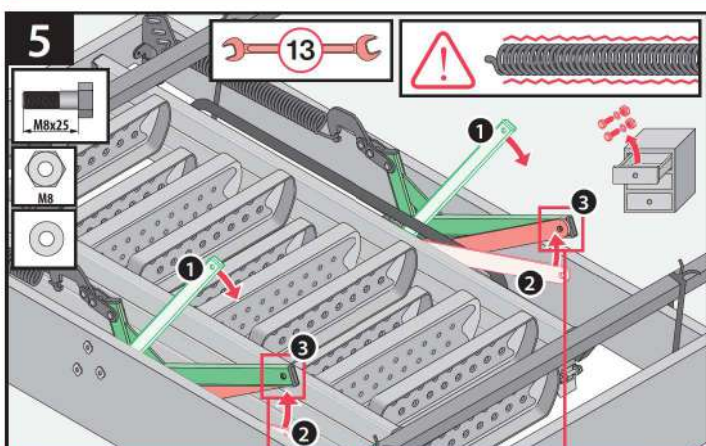
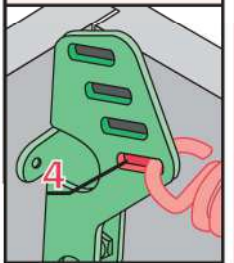
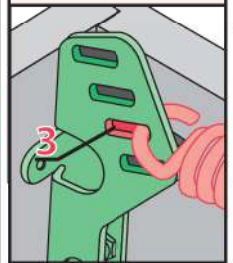
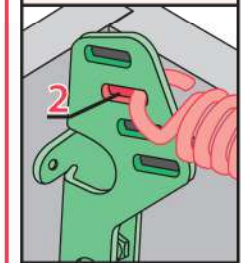

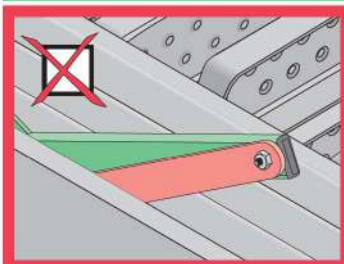
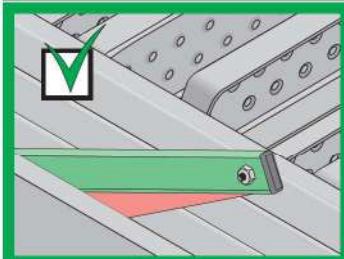
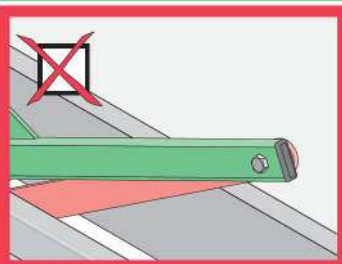
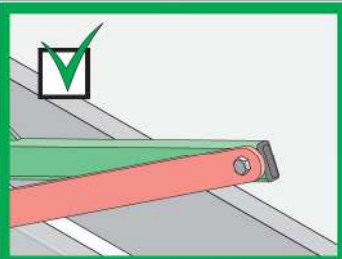
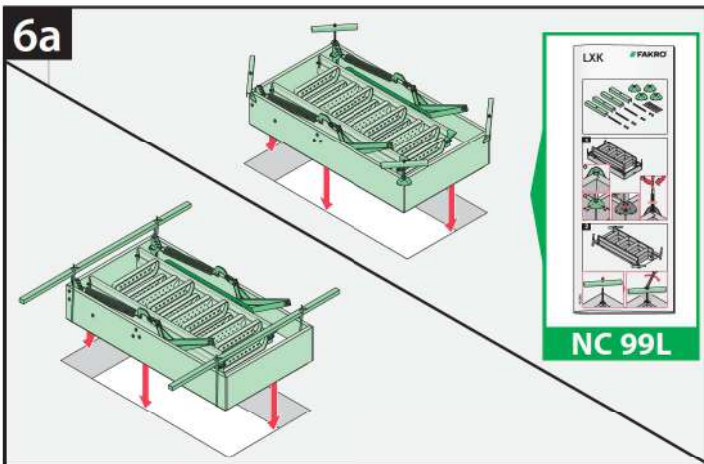
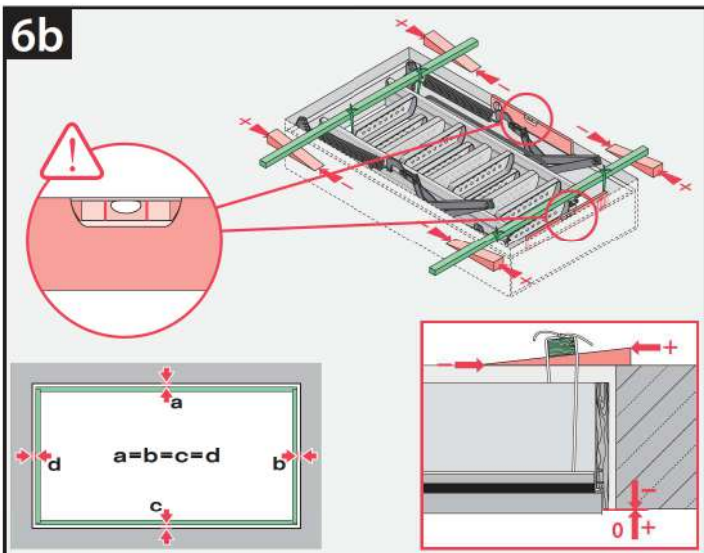
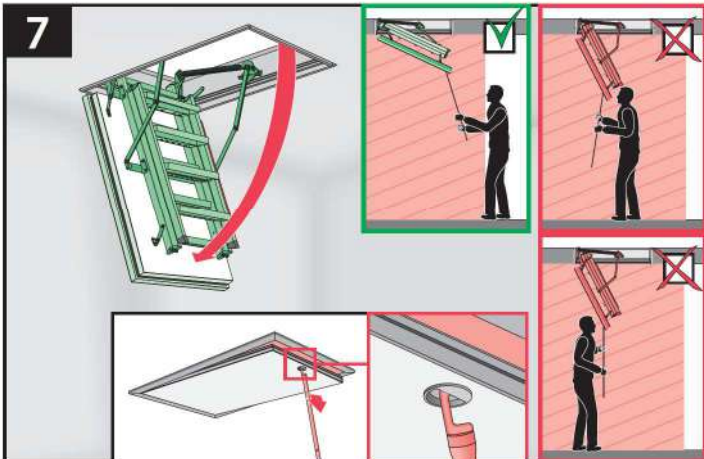
L**R****6a****6b****7**



8



8*

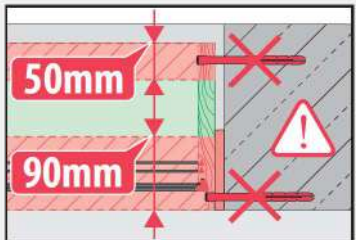
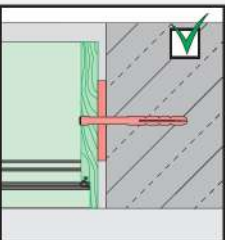
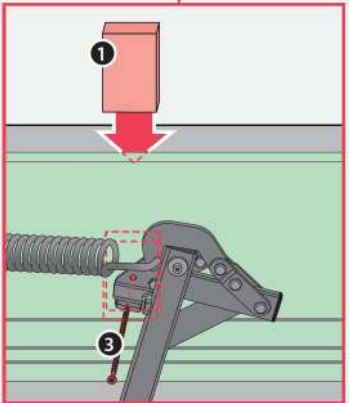
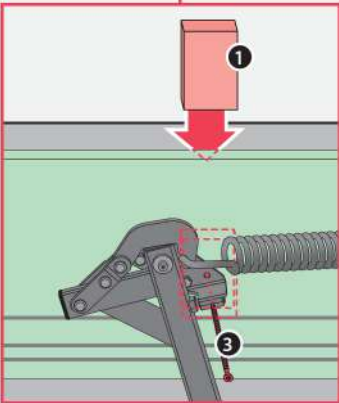
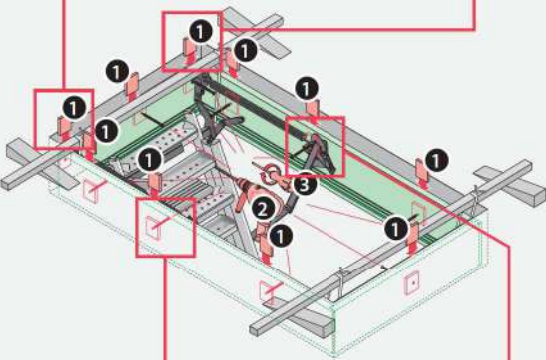
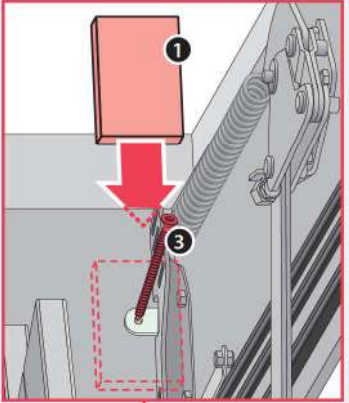
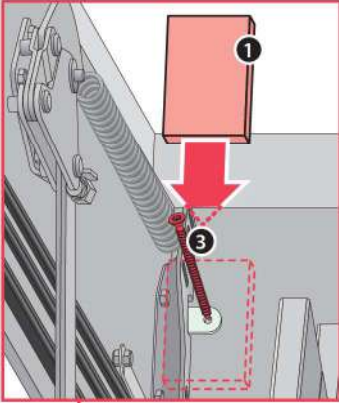

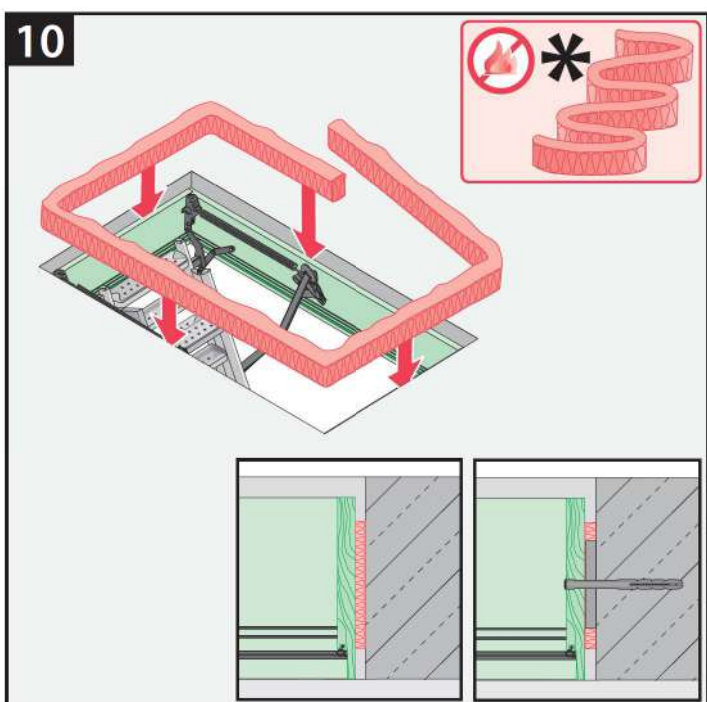
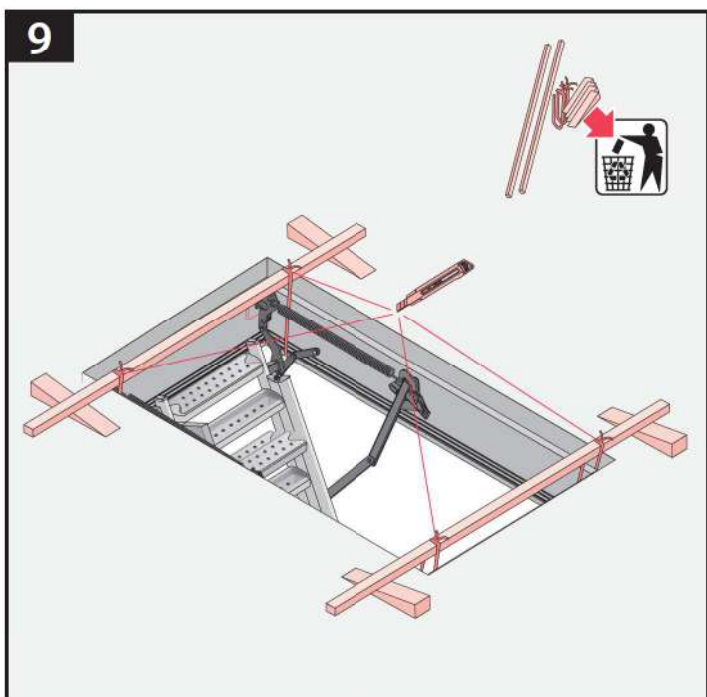
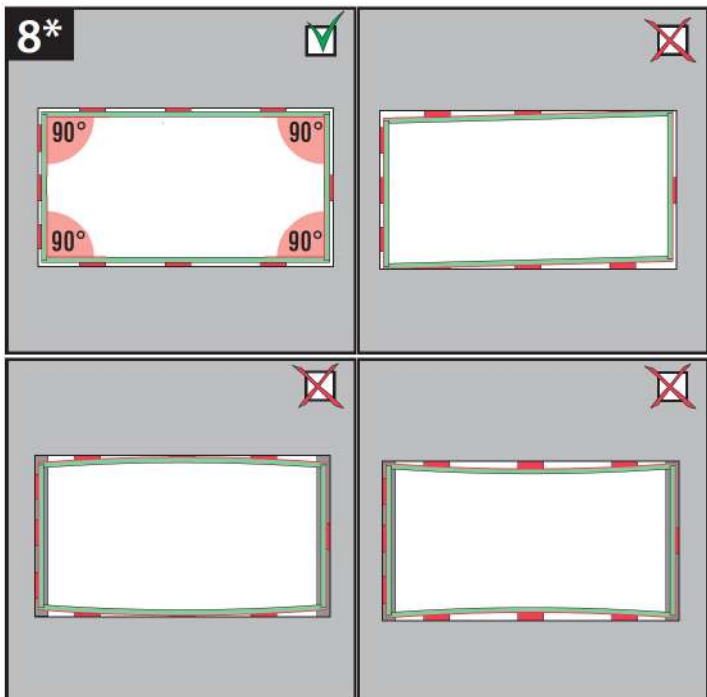

11

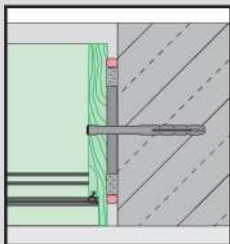
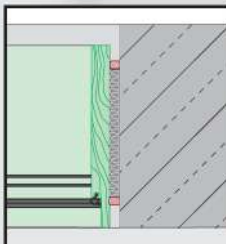
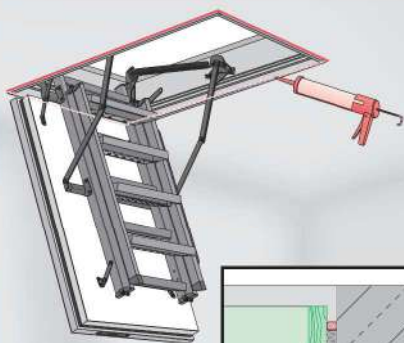
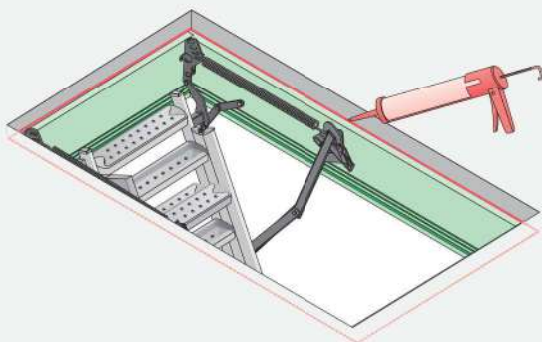

12

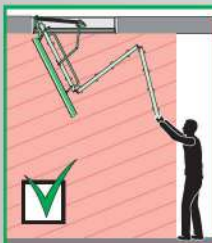

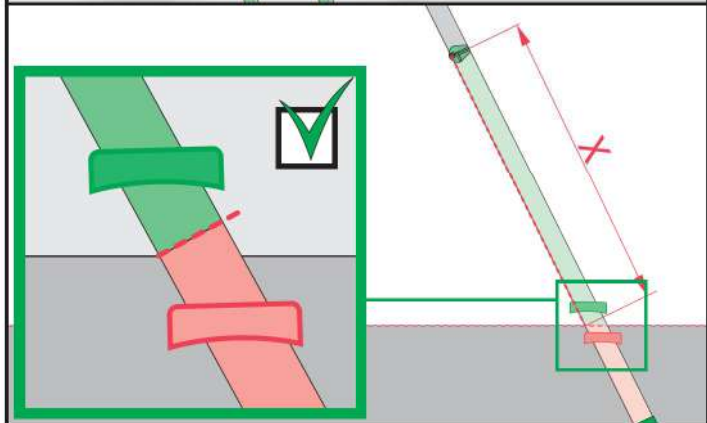
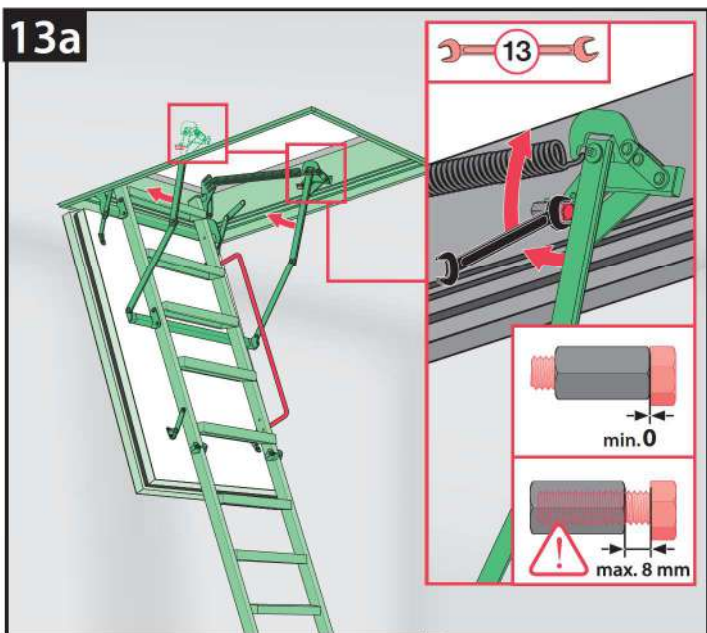
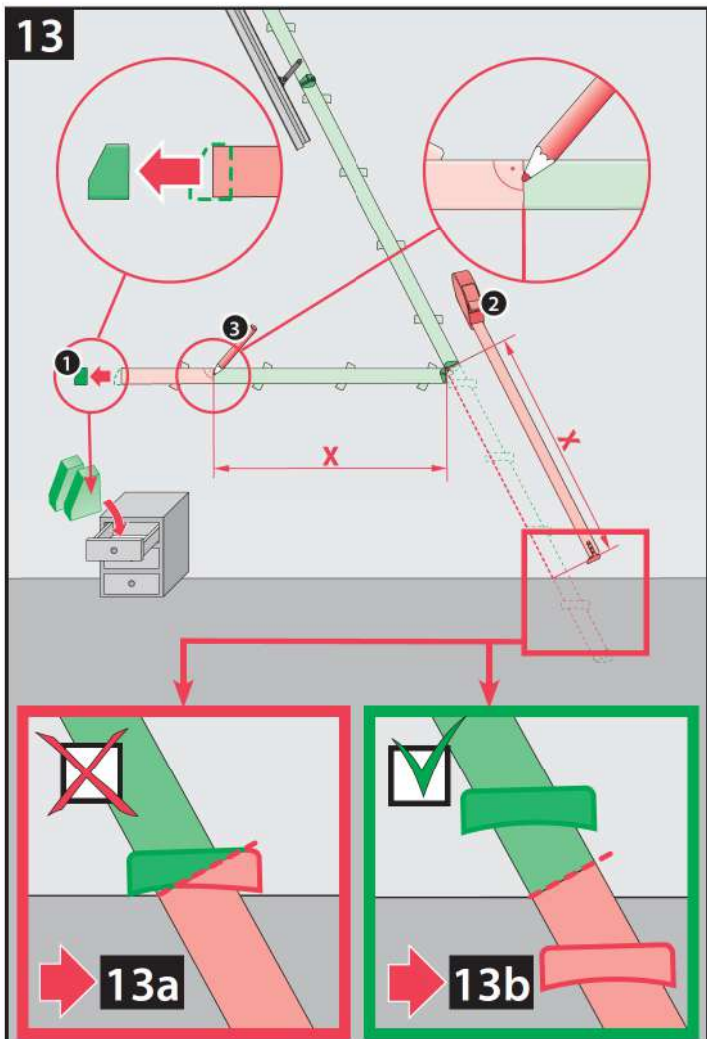

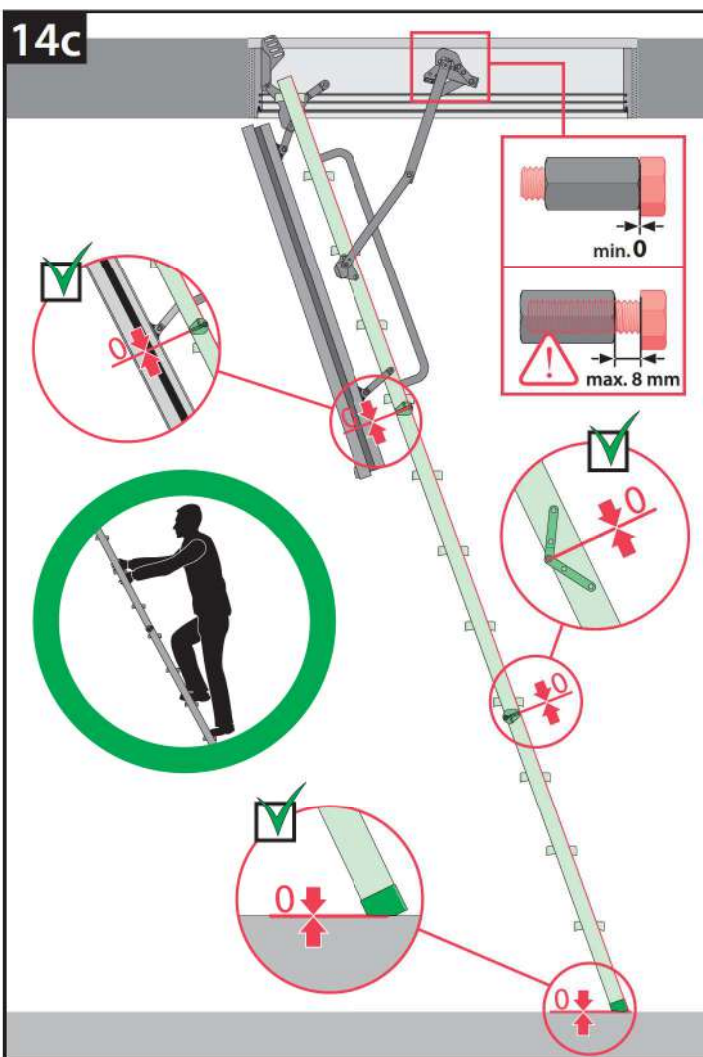
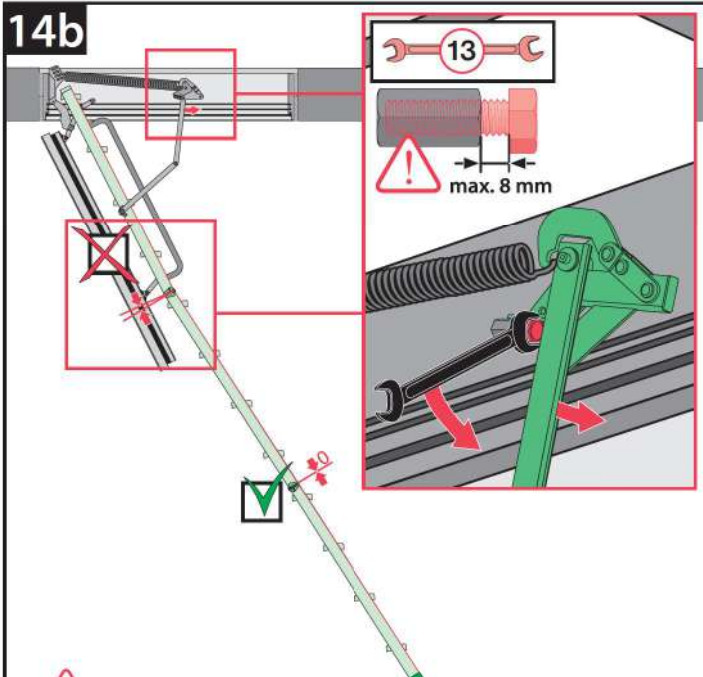

15

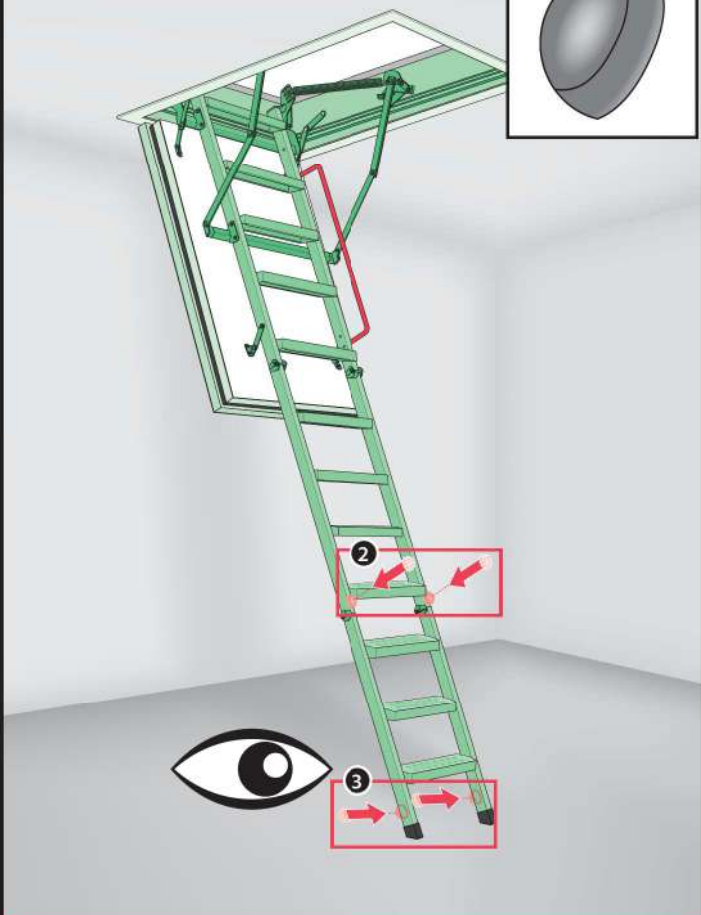
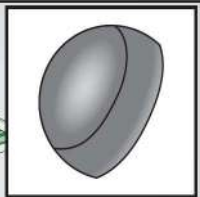

1

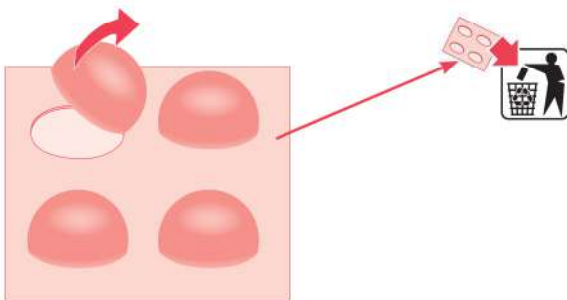

2

~70 mm

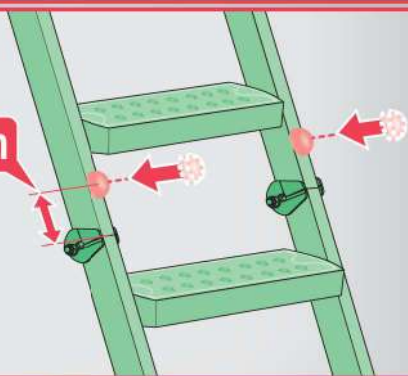

3

~70 mm

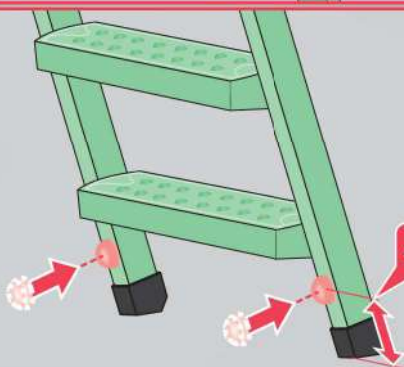

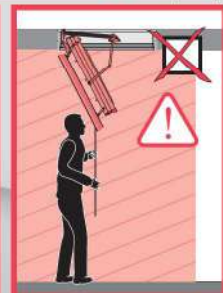
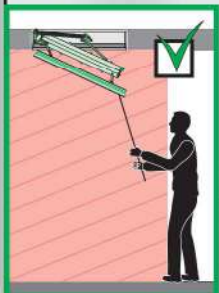
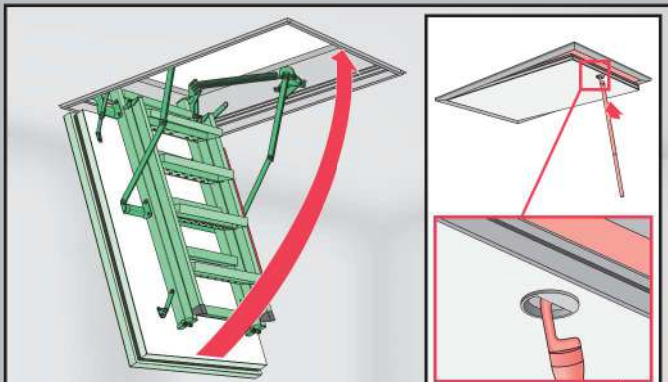
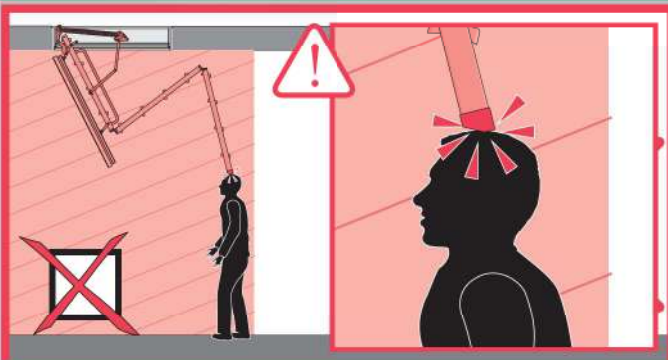
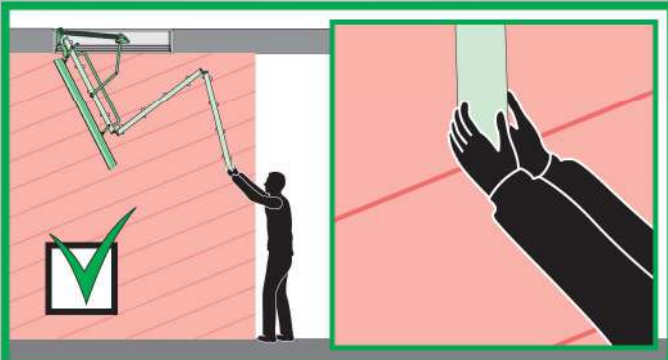

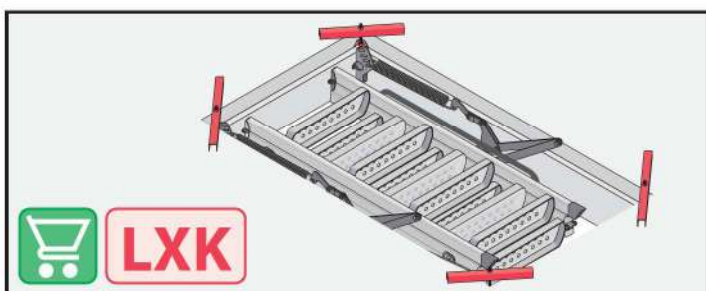
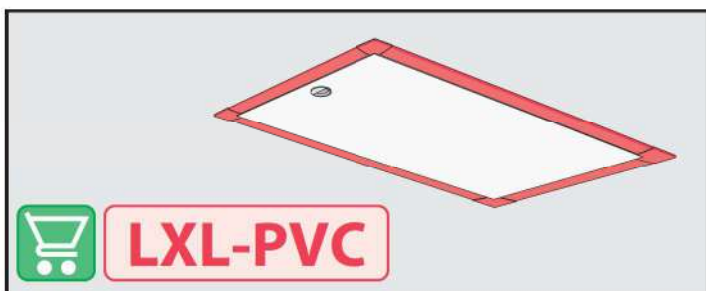
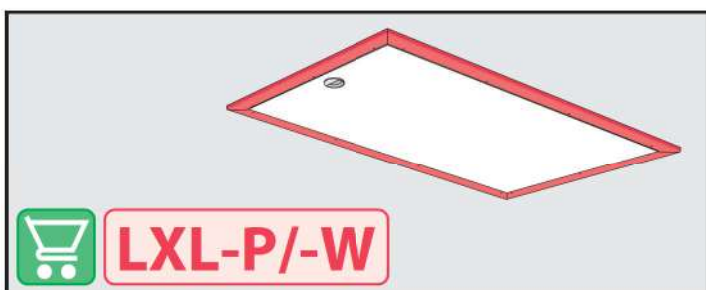
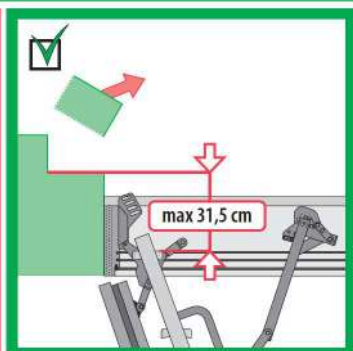
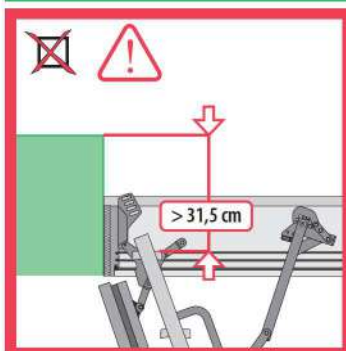
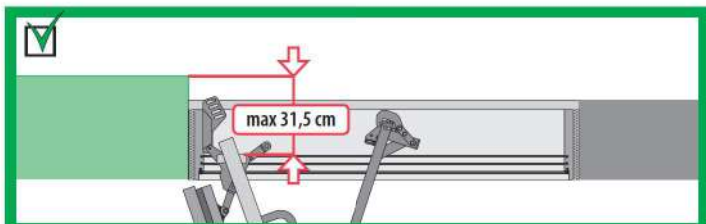

! WARNING! - ACHTUNG! - UWAGA! - ATTENTION! - ВНИМАНИЕ!



FEUERHEMMENDE BOEDENTREPP
 ESCALIER ESCAMOTABLE COUPE-FEU
 FIRE-RESISTANT LOFT LADDER
 SCHODY SEGMENTOWE OGNIODPORNE

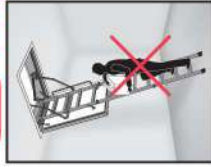
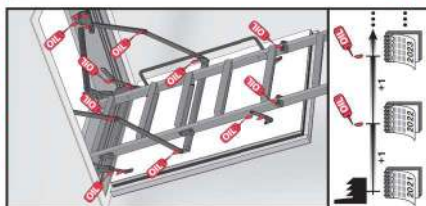
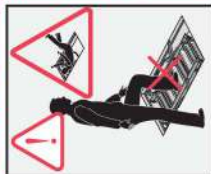

**SAFETY! - SICHERHEIT! - BEZPIECZEŃSTWO!
 SECURITÉ! - SEGURIDAD! - БЕЗОПАСНОСТЬ!**
<https://www.fakro.com/service/safety-instructions/>

EN 14975

FAKRO
www.fakro.com

Wyrób wprowadzony do obrotu na zasadzie wzajemnego uznawania zgodnie z Art. 5 (punkt 5.3) ustawy o wyrobach budowlanych z dnia 16 kwietnia 2004 r. (Dz.U. Nr 92, poz. 881 z póź. zm.) i Rozporządzenia Parlamentu Europejskiego Rady (UE) 2019/515 z dnia 19 marca 2019 w sprawie wzajemnego uznawania towarów zgodnie z prawem wprowadzonych do obrotu w innym państwie członkowskim.



BG	Производител и Продавач не носят отговорност за неспазване на съответните закони, строителни норми и изчисления за безопасност от потребление на продукта, архитекта, монтажника или собственика на сградата.	IT	Il Produttore e il Rivenditore non potranno essere ritenuti responsabili per il mancato rispetto, da parte dell'utente del prodotto, del progettista, dell'installatore o del proprietario dell'edificio, delle leggi vigenti, nonché dei regolamenti edilizi e di quelli relativi alla sicurezza.
CZ	Výrobce ani prodejce nenesou žádnou odpovědnost za nedodržení příslušných platných zákonů, stavebních předpisů a bezpečnostních požadavků uživateli výrobku, architektem, montážníkem nebo vlastníkem budovy.	NL	De fabrikant en verkoper zijn niet aansprakelijk voor gevolgen bij het niet opvolgen van toepasselijke wetten, bouwbesluiten en veiligheidsvoorschriften door de gebruiker van het product, de architect, de installateur of de eigenaar van het gebouw.
DE	Hersteller und Verkäufer übernehmen keine Haftung für Nichtbeachtung entsprechender Rechts- und Bauvorschriften sowie Sicherheitsanforderungen seitens Produktbenutzers, Architekten, Monteure oder Gebäudebesitzers.	PL	Producent i Sprzedawca nie ponosi żadnej odpowiedzialności za nieprzestrzeganie stosownych przepisów prawa, przepisów budowlanych i wymagań bezpieczeństwa przez użytkownika produktu, architekta, montażystę lub właściciela budynku.
ES	El fabricante y el vendedor no tienen ninguna responsabilidad por el incumplimiento de la ley vigente, normas de construcción y exigencias de seguridad por parte del usuario del producto, arquitecto, instalador o el propietario del edificio.	PT	O fabricante e o vendedor não tem nenhuma responsabilidade pelo o não cumprimento das leis, códigos de construção e as exigências de segurança por parte do usuário do produto, arquiteto, instalador ou proprietário do edifício.
FR	Le fabricant et le revendeur ne prend aucune responsabilité de ne pas respecter les lois applicables, les règlements sur les bâtiments et les exigences de sécurité par l'utilisateur du produit, l'architecte, l'installateur ou le propriétaire du bâtiment.	RO	Nici producătorul, nici distribuitorul nu își vor asuma niciun fel de răspundere pentru nerespectarea legilor în vigoare, a legilor din domeniul construcțiilor sau a măsurilor de siguranță impuse utilizatorilor produsului, arhitecților, montajorilor sau proprietarilor clădirii.
GB	Manufacturer and Seller shall bear no liability for failure to comply with the applicable laws, building codes and safety requirements by the user of the product, architect, fitter or owner of the building.	RU	В случае необходимости архитекторами, монтажниками или владельцами здания строительных правил и норм безопасности ответственности с производителя и продавца снимаются.
HU	A Gyártó és a Forgalmazó nem vállal semmilyen felelősséget a vonatkozó törvényi, építészeti és biztonságági előírások betartásának, építész, beépítésmester vagy épületajánlóknak általi be nem tartásáért.	SK	Výrobca a predajca nenesú žiadnu zodpovednosť za nedodržanie príslušných ustanovení zákona, stavebných predpisov a bezpečnostných požiadaviek užívateľmi výrobku, architektom, montérom alebo majiteľom objektu.