

Retro S



RAL: 1013

Retro S

Predisposizioni

Ad acqua calda



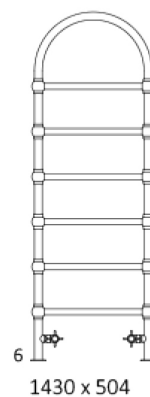
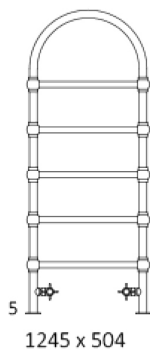
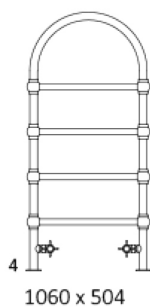
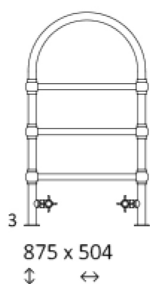

Dimensioni disponibili



Retro S

Informazioni tecniche :

Pressione del lavoro : 1.0MPa Temperatura massima di lavoro : 95°C

A ↓	B ↔	C4 [mm]	75 65 20°C [W]	55 45 20°C [W]	D [mm]	E [mm]	 [dm³]	 [kg]
Vernice possidica								
875	504	400	221	113	450	570	2,32	6,80
1060	504	400	266	136	450	755	2,73	8,30
1245	504	400	311	159	450	940	3,15	9,70
1430	504	400	356	181	450	1125	3,57	11,10
Rivestimento galvanico								
875	504	400	155	79	450	570	2,32	6,80
1060	504	400	186	95	450	755	2,73	8,30
1245	504	400	218	111	450	940	3,15	9,70
1430	504	400	249	127	450	1125	3,57	11,10

Retro S

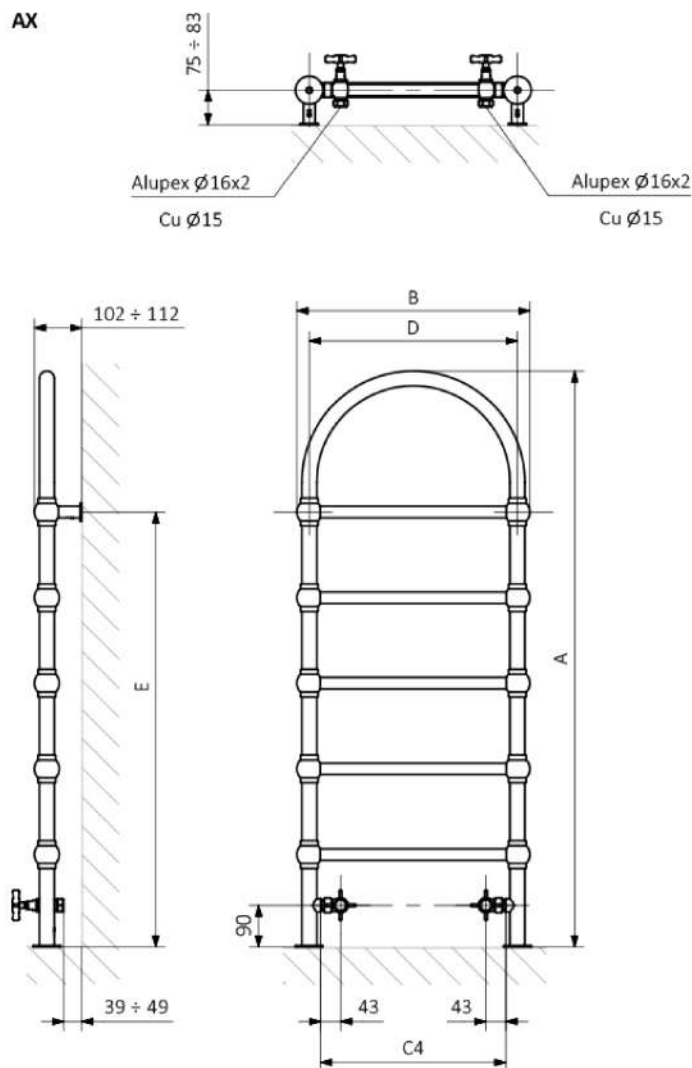

A - Altezza / B - Larghezza / C1-C5 - Distanza tra i raccordi / D - Interasse tra i tubi verticali / E - Distanza tra i punti di fissaggio / F - Distanza dell'asse del punto di fissaggio inferiore al bordo inferiore dello scaldasalviette

Collettore:

Profilo:

