

L'emballage de l'escalier comprend toujours une lisse basse spécifiant les positions exactes des trous à percer sur la structure et pour fixer la rampe. Couper la lisse basse selon la largeur de l'escalier et la positionner correctement au-dessus de la marche. REMARQUE: Pour le P3, positionner la lisse basse sur la marche en la faisant coïncider avec les côtés relatifs "interne escalier" et "arrière marche", selon les indications spécifiées sur la lisse basse. Les indications de perçage spécifiées au centre se réfèrent à la structure (St), tandis que l'indication du perçage "latéral" se réfère à la fixation de la rampe (R) (Fig. 4). Pour fixer la rampe dans les marches droites, il est nécessaire de percer d'autres trous: si l'on considère que le premier trou a déjà été percé au préalable à l'aide de la lisse basse, percer les deux autres trous à une distance égale à la moitié du giron (P/2), l'un de l'autre (Fig. 5).

CALCUL DU GIRON

Mesurer la longueur de la trémie L1 qui correspond à la dernière volée (Fig.6).

Soustraire à la dimension L1 de la trémie:

- la dernière marche avec le giron fixe à 29 cm
- la dimension du côté de l'éventail (70, 80 ou 90 selon la largeur de l'escalier)
- un centimètre d'écart par rapport au mur

Diviser la valeur obtenue par le nombre de marches droites de la volée moins un.

Le résultat de l'opération doit donner une valeur (giron) comprise entre 20 et 22,5 pour une largeur 75 et entre 22,5 et 25 pour 85 ou 95 de largeur.

Exemple: $(184-29-70-1) : 4 = 20$

Exemple: $(216-29-90-1) : 4 = 24$

CALCUL DE LA CONTREMARCHE A

Mesurer la hauteur du sol de départ au sol d'arrivée de l'escalier HT. Considérer que la première contremarche a une hauteur fixe de 19,0 tandis que les contremarches intermédiaires ont une hauteur variable comprise entre 18,5 au minimum et 22,5 au maximum (Fig. 7). Pour calculer la contremarche, prendre en considération la typologie de palier d'accès de l'escalier; au dessous de la dalle (S.S.) si la marche d'arrivée est située sur une contremarche inférieure par rapport au niveau du sol (Fig. 9) ou bien au niveau du sol (F.P.) si la marche palière est située à la hauteur du sol (Fig. 8).

Calculer la contremarche A de l'escalier de la façon suivante :

Arrivée Dessous Dalle :

Diviser la valeur de la HT par le numéro de marches de l'escalier + 1.

Arrivée Niveau Sol :

Diviser la valeur de la HT par le numéro de marches de l'escalier.

Exemple d'escalier avec 13 marches et une HT = 280.

Contremarche moyenne avec palier d'accès "Dessous de la Dalle" : $A = HT : 14 = 20$

Contremarche moyenne avec palier d'accès "Niveau du Sol" : $A = HT : 13 = 21.5$

ASSEMBLAGE DES STRUCTURES

Assembler le module d'arrivée (Fig. 10) avec les compensateurs correspondants (voir tableau 43-45 pag. 22) et ajouter autant d'entretoises qu'il faut pour obtenir la contremarche calculée. Positionner correctement la plaque du support d'arrivée sur la dalle. Si le palier d'accès est à Niveau du Sol, pour éliminer la distance de la plaquette d'arrivée il est nécessaire d'assembler la marche au module d'arrivée, en reculant de 0,8 par rapport au perçage situé au-dessous de la marche (Fig. 8). Percer la dalle à l'aide d'une mèche de Ø 14 mm et y bloquer la plaquette d'arrivée à l'aide des chevilles à expansion relatives (Fig. 10). Assembler un module intermédiaire et le visser au palier d'accès déjà fixé (Fig. 11-12); par la suite, assembler tous les modules qui restent. Pour soutenir les 4/5 premières structures libres, il est conseillé de positionner un étau (Fig. 13). Faire bien attention à la pose des modules, puisqu'ils doivent être parfaitement en ligne entre eux (Fig. 14). Les bouchons ainsi que leurs lamelles internes sont insérés au moyen d'une pression exercée sur les structures. Nous conseillons de monter les bouchons seulement après avoir terminé l'assemblage de toutes les structures.

FIXATION AU SOL

Fixer la plaquette de départ au module par les vis spécifiques (Fig. 15); par la suite, positionner la structure de départ au-dessous du module intermédiaire précédent, qui est déjà installé. Marquer le sol et déplacer le premier support, ce qui permet de percer le sol. Remettre en place le module et le fixer au sol par les chevilles à expansion, les barres et les écrous borgnes (Fig. 16).

ASSEMBLAGE DES MARCHES/STRUCTURES

Positionner correctement les marches percées au préalable au-dessus des modules et les fixer à ceux-ci par les vis autotaraudeuses spécifiques (Fig. 17).

SUPPORT LATERAL

Le support latéral peut se substituer à un support au sol, faisant référence aux configurations aux pages 18-22 pour un correct positionnement. Reportez-vous à l' *Annexe 1: Fixations* avant de procéder avec l'ancrage à la paroi. Fixer le support latéral femelle au support relatif de la structure. Mesurer la distance X , couper le support latéral mâle à $X+15$ et le fixer au support latéral femelle. Positionner la marche pourvue de support latéral en séquence par rapport aux autres marches déjà installées et marquer sur la paroi les trous de la plaque. Percer la paroi à l'aide d'une mèche de \varnothing 14 mm et introduire les chevilles à expansion relatives. Assembler la marche selon la même procédure (accomplir les opérations décrites ci-dessus) et fixer à la paroi le support latéral, ainsi que les barres filetées et les écrous borgnes relatifs (Fig. 18-19-20-21).

CONSOLE POUR LA MARCHÉ

Procéder avec l'assemblage des tablettes des marches. Pour mieux stabiliser l'escalier, disposer une tablette environ toutes les trois marches (Fig. 22).

SUPPORT AU SOL

Pour définir la position correcte du soutien au sol se référer aux configurations aux pages 18-22. Mesurer la hauteur du sol à la marche Q_g , au-dessous de laquelle on doit positionner le support (Fig. 23). Insérer la rallonge dans la partie servant de soutien qui se trouve à terre, afin d'obtenir une hauteur de $Q_g - 18$ (Fig. 24), si la rallonge ne repose pas sur la base, assembler les deux composants comme sur la Fig. 25. Pour des hauteurs ($Q_g - 18$) inférieures à 114, il faut faire couper la rallonge sur mesure. Fixer la plaque au sol par les chevilles à expansion spécifiques; fixer le support au module, à l'aide de la vis métrique (Fig. 26).

ASSEMBLAGE DE LA RAMPE :

FIXATION DES LOQUETEAUX

La fixation des balustres de la rampe se fait par des "loqueteaux" qui doivent être fixés sur le côté inférieur de la marche. Chaque marche comprend 3 loqueteaux ; pour les positionner de façon correcte, voir les perçages exécutés précédemment (voir point 1) (Fig. 27). Bloquer les balustres par les loqueteaux et fermer les bouts de ceux-ci par les bouchons en plastique relatifs; enfin, régler la position du balustre traversant deux marches (Fig. 28).

FIXATION DES BALUSTRES

Le balustre traversant a une hauteur figée de 116,5 tandis que le balustre central doit être coupé sur mesure, selon la formule $116,5 - A/2$, et doit être positionné au-dessous de la marche d'1,5 environ (Fig. 29). Assembler les balustres du tournant par le joint relatif et les couper sur mesure au niveau de la partie inférieure de la dernière marche (Fig. 30). Si le palier d'accès est au-dessous de la dalle, placer un loqueteau à 2,2 cm par rapport au coin arrière de la marche palière ; enfin, fixer le dernier balustre dans le plancher à l'aide d'un loqueteau en métal (Fig. 31). Sur la marche de départ, le balustre doit être coupé d' $A-1,3$ et doit être réglé à l'intérieur du manchon qui doit être fixé au sol (Fig. 32).

Pour la rampe externe éventuelle du tournant, garder toujours une distance d'environ $P/2$ parmi les balustres (Fig. 33).

ASSEMBLAGE DE LA MAIN COURANTE

Installer le raccord "sommel" (Fig. 34) afin de fixer les balustres à la main courante par les vis autotaraudeuses spécifiques (Fig. 35). Pour joindre la rampe entre la première et la deuxième volée, utiliser l'anneau spécifique du balustre et le fixer par le raccord et le bouchon relatifs de la main courante (Fig. 36). Pour joindre plusieurs parties de main courante, utiliser une barre filetée et un disque d'écartement (Fig. 37). Pour des parties orthogonales de main courante, utiliser un raccord à 90° (Fig. 38). Pour joindre deux parties de main courante, en cas de pentes différentes, utiliser deux bouchons et le raccord relatif de la main courante, en le pliant selon l'inclinaison de l'escalier (Fig. 39).

GARDE-CORPS

Si la main courante du garde-corps est positionnée à la butée d'une paroi, la percer (Fig. 40) et la fixer au mur par une cheville à expansion (Fig. 41). Pour un assemblage correct, les balustres du garde-corps doivent avoir une distance suffisante du coin de la dalle, ce qui évite toute rupture (Fig. 42); de plus, ils doivent être fixés au sol par des chevilles à expansion (Fig. 42-A). Pour un raidissement supérieur, raccorder la volée de l'escalier d'arrivée au garde-corps par un "crochet du balustre" (Fig. 42-B), positionner le "balustre d'arrêt" (Fig. 42-C) et fixer le dernier balustre au mur par le "crochet du balustre" (Fig. 42-D).

Note: pour insérer les base et les éléments cima dans les balustres utiliser un marteau en caoutchouc

SCHEMAS

À la page 22, sont reportés les schémas où figure le réglage correct des structures et les indications de montage pour les modules d'arrivée, dans les différents cas.

- (Fig. 43) *Arrivée avec marches droites* – Le Giron de la marche d'arrivée (P-Sb), la valeur Y, et le compensateur à utiliser sont indiqués en cas d'arrivée avec marche droite.

N.B. La marche d'arrivée est une marche standard d'une profondeur de 29 cm

- (Fig. 44) *P3 intermédiaire* – Les pas des structures (valeurs a, b, c, d) sont indiqués pour les trois largeurs de marche (Lg).

- (Fig. 44a) *P3 intermédiaire* – Les distances entre le bord antérieur de la structure et le bord antérieur de l'entretoise sont indiquées. Cette distance est identique au pas des structures plus 1,8 cm.

- (Fig. 45) *P3 d'arrivée avec rampe* – On indique la position Y et les compensateurs à utiliser avec la structure d'arrivée

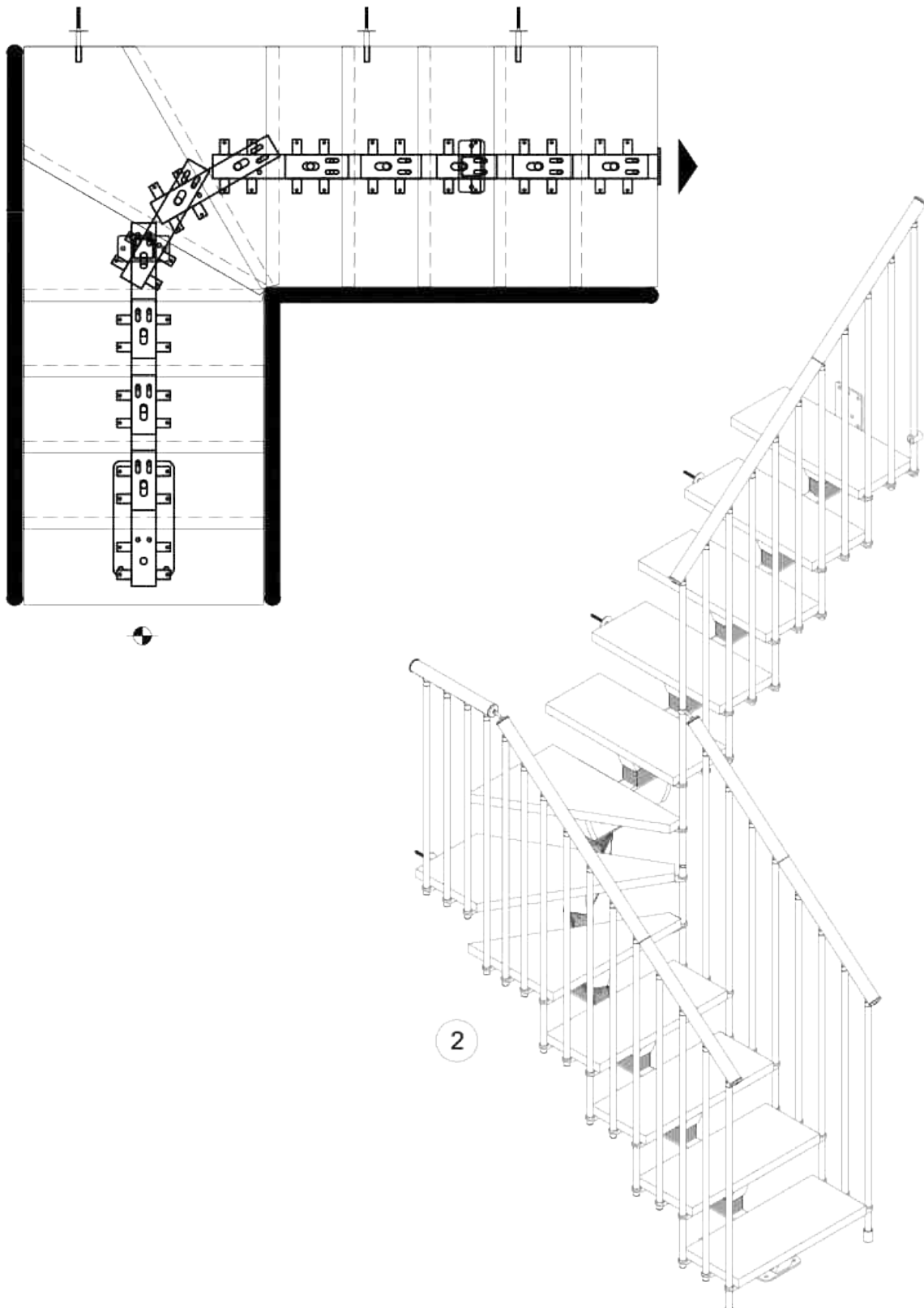

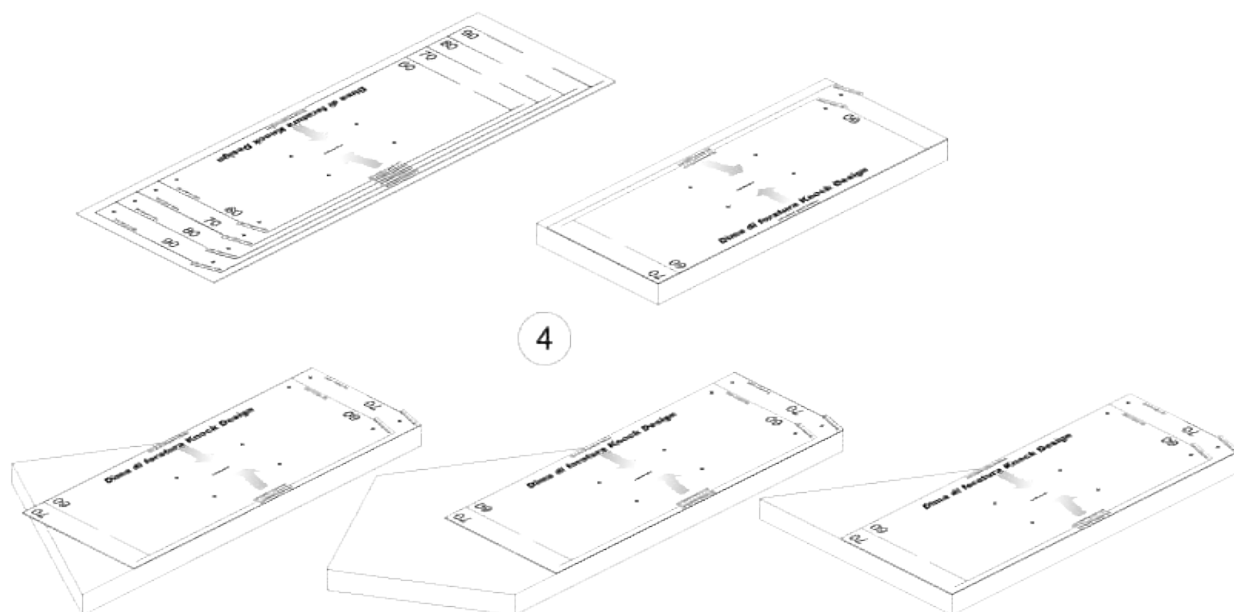
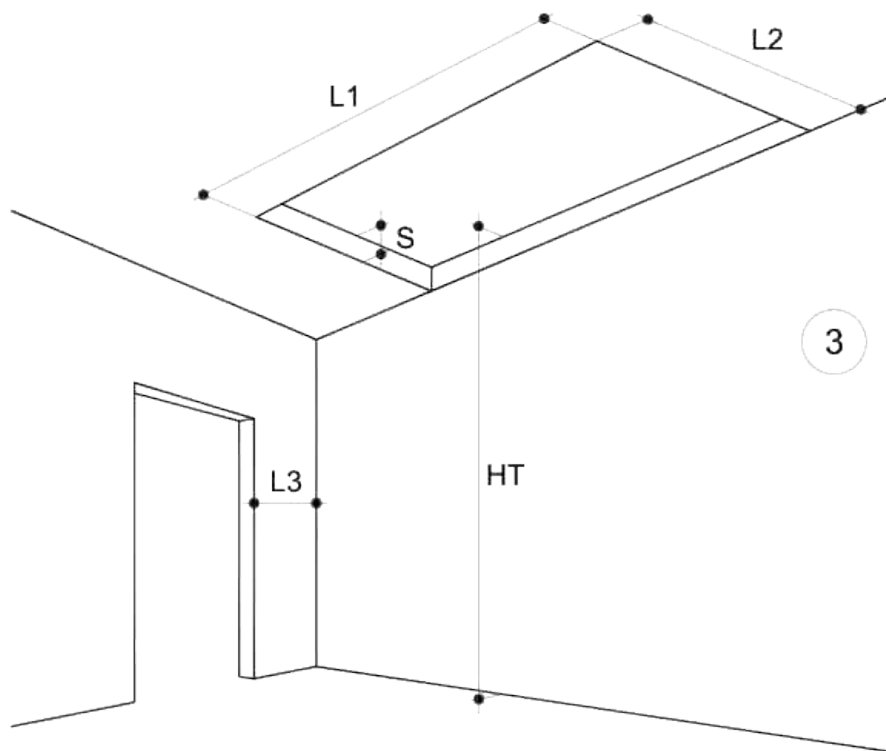

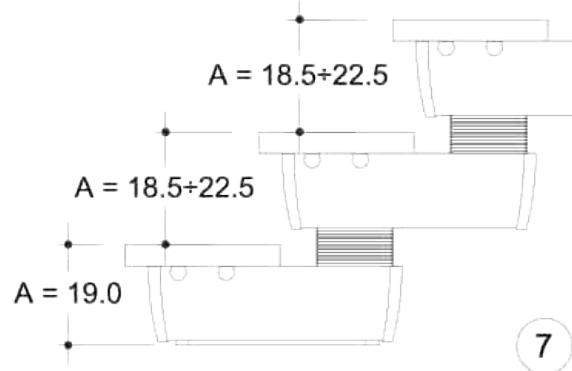
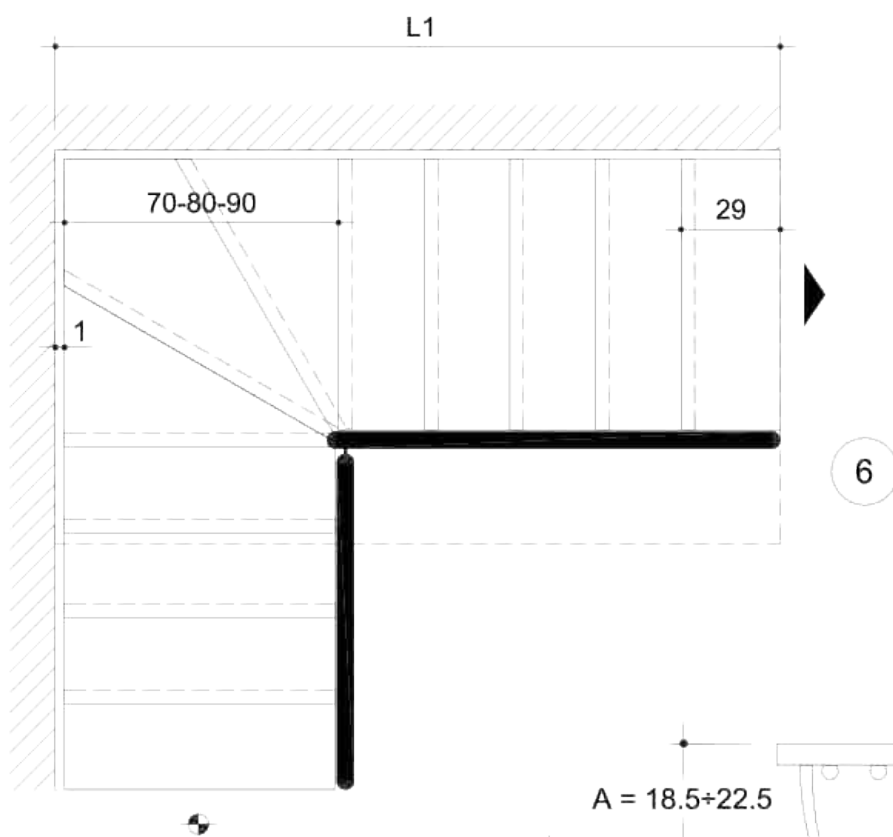

8

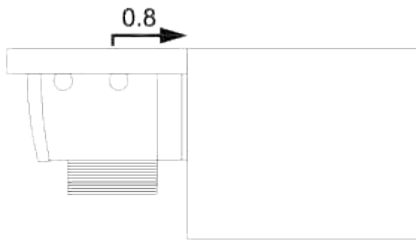

9

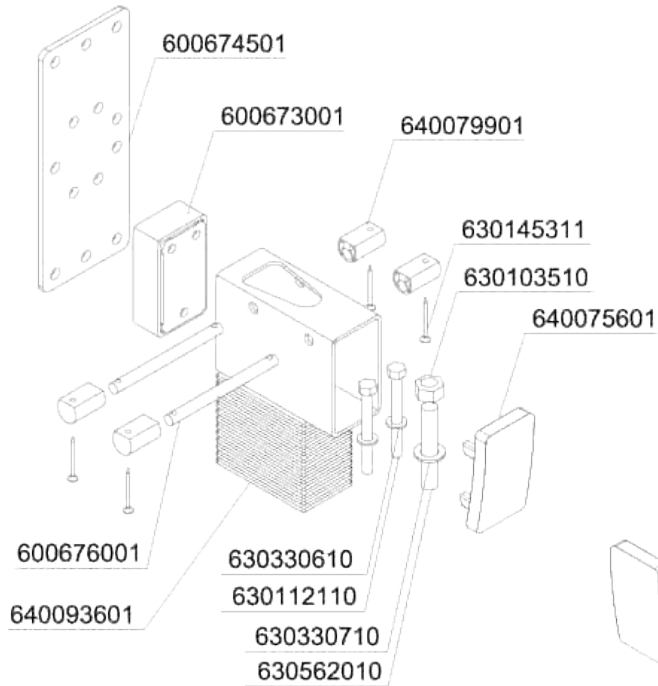
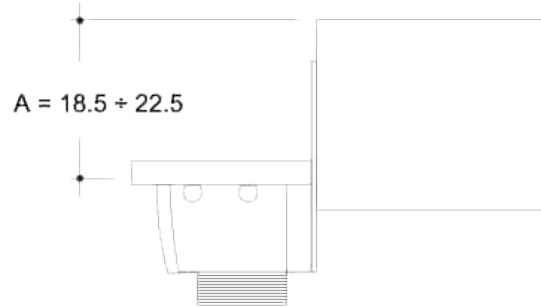

10

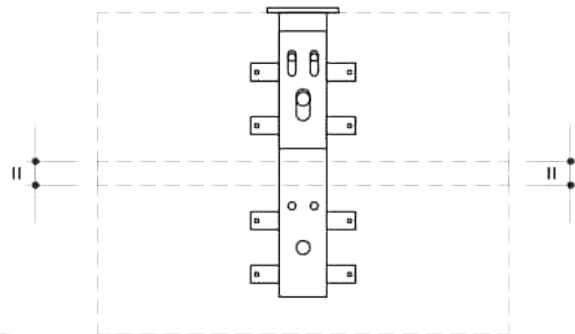
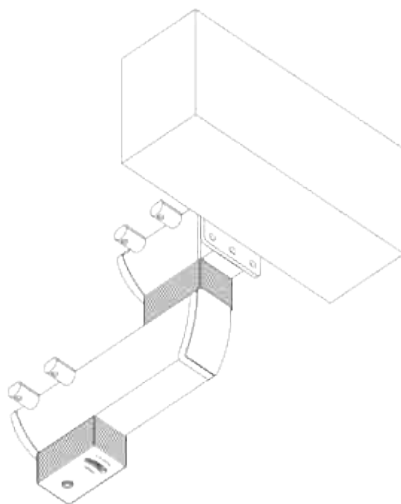
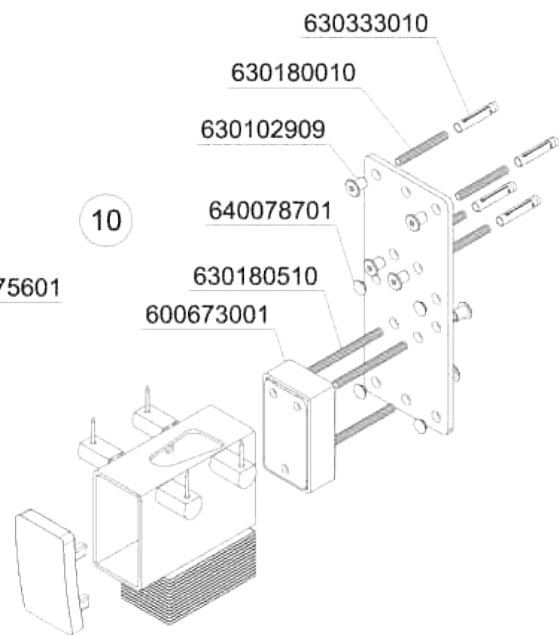

11

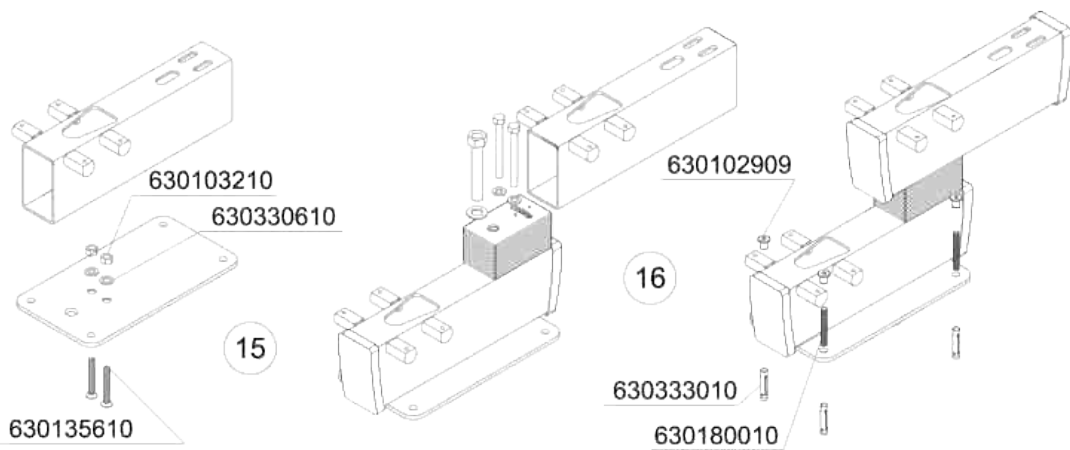
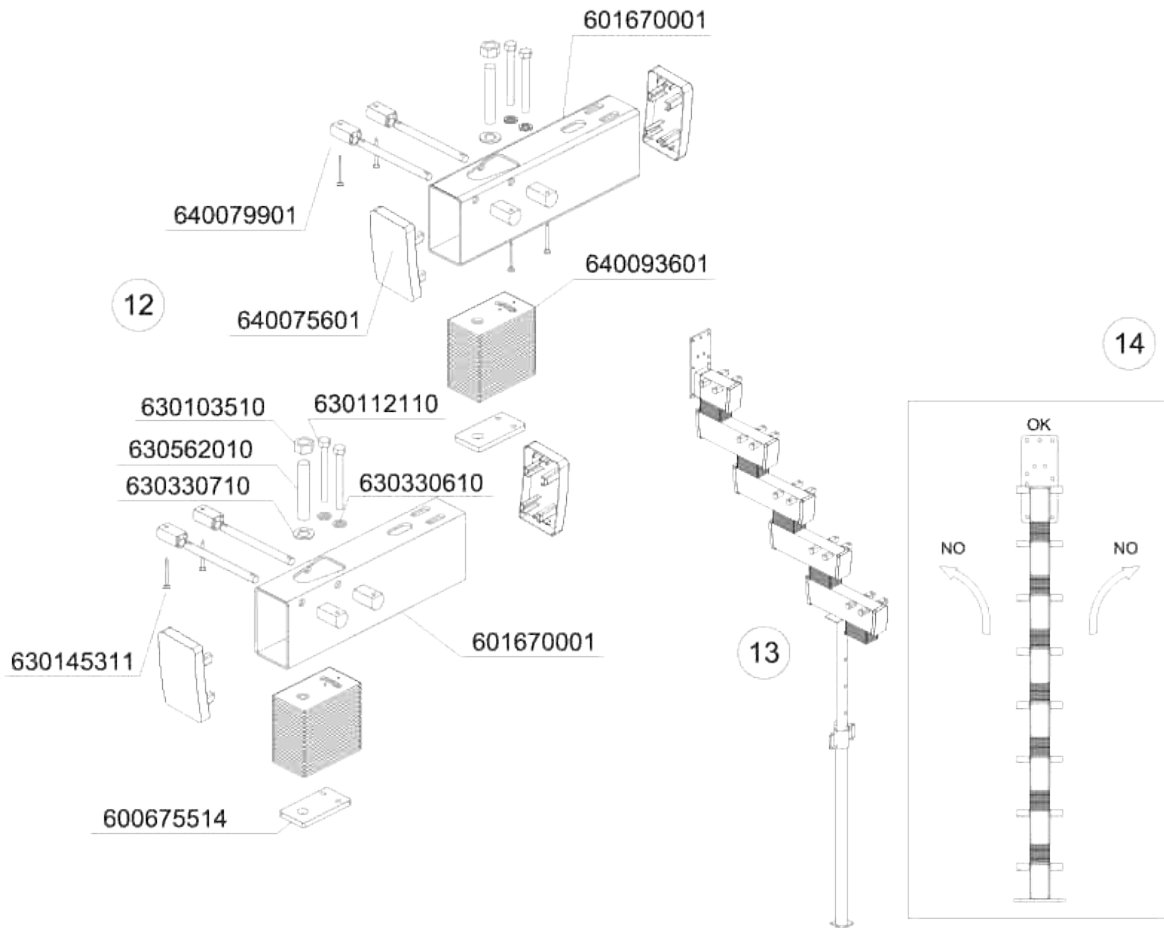

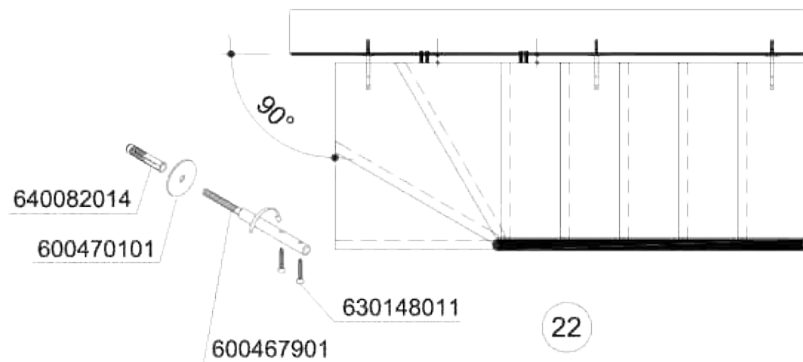
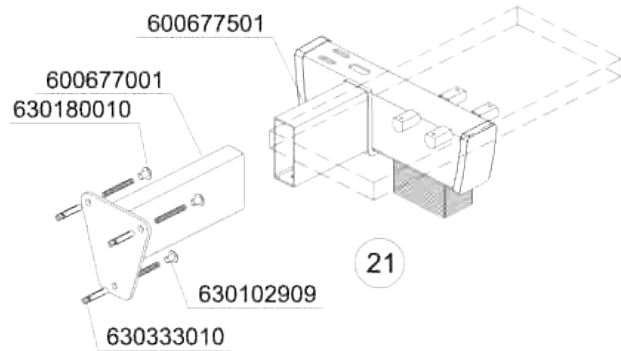
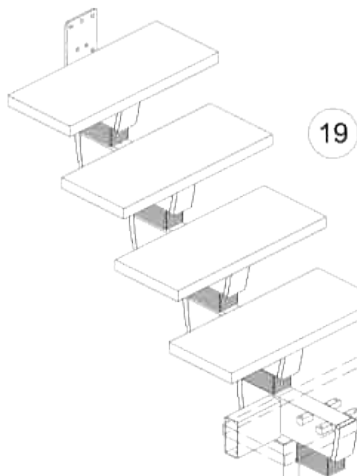
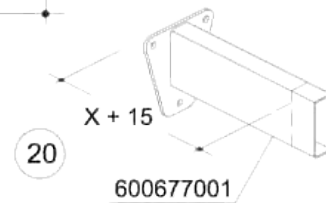
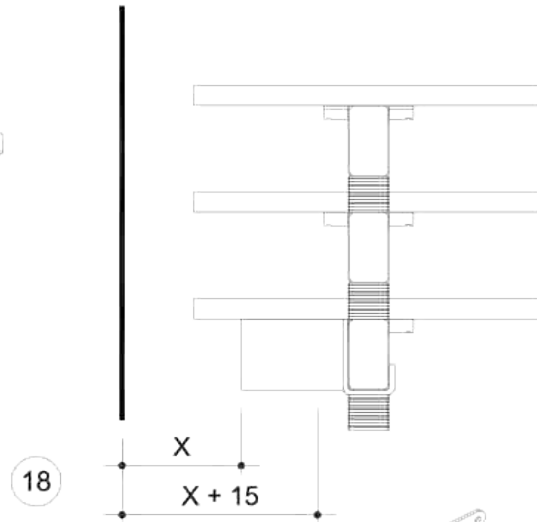
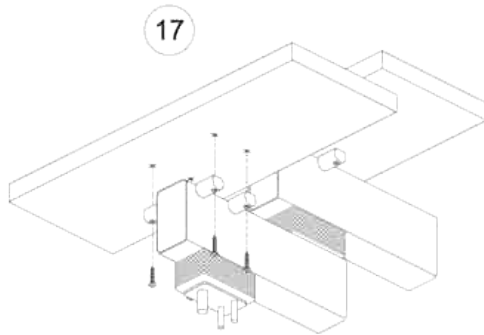

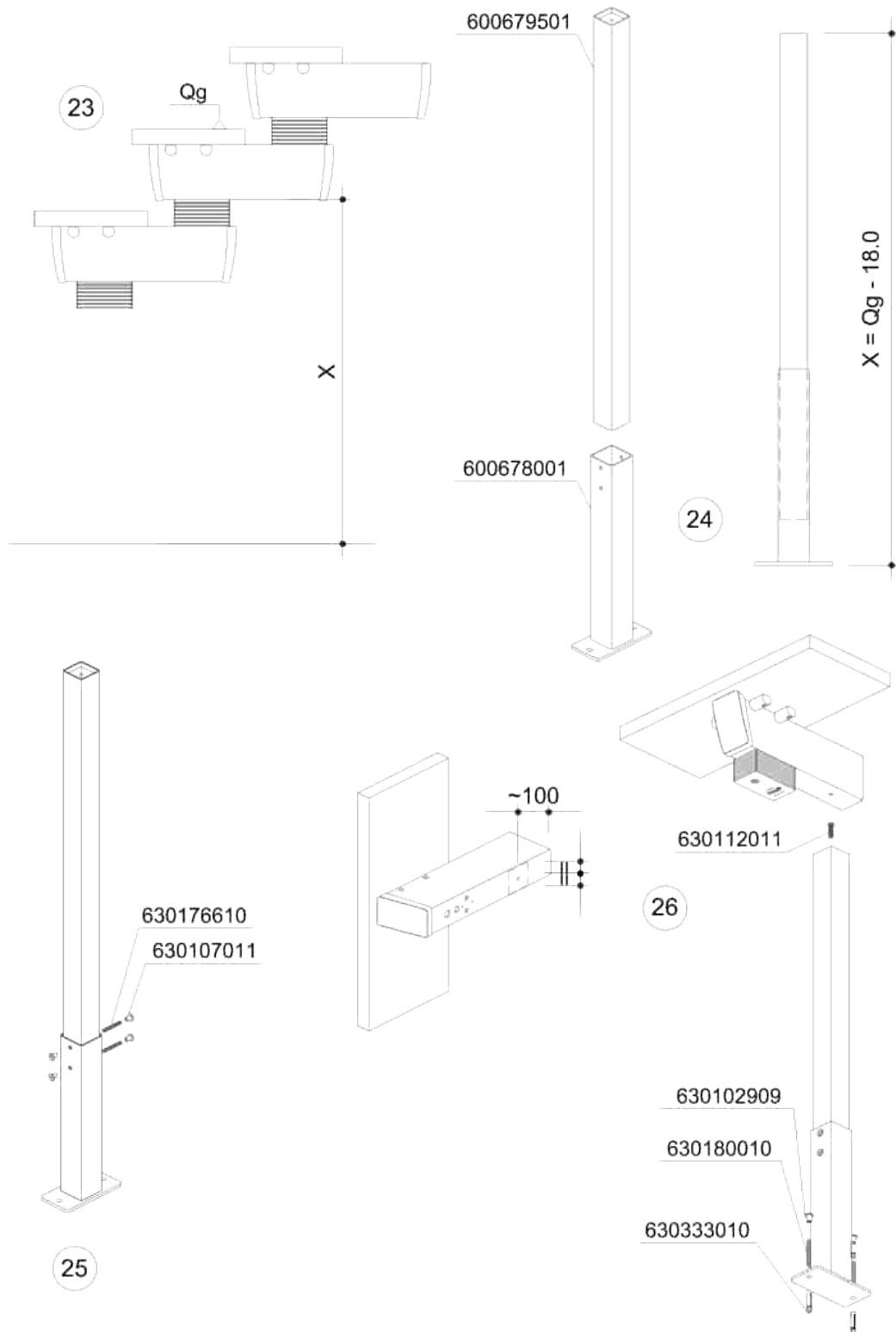

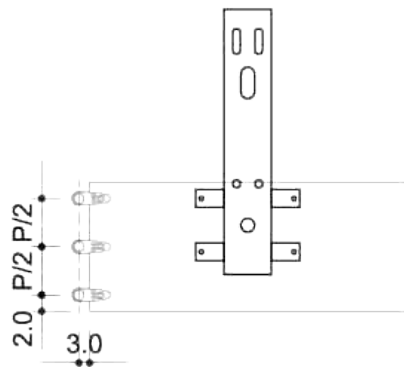

27

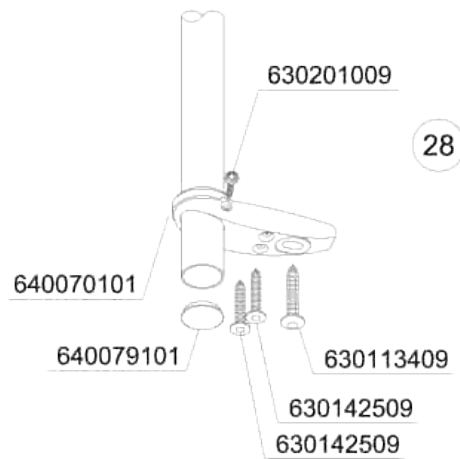
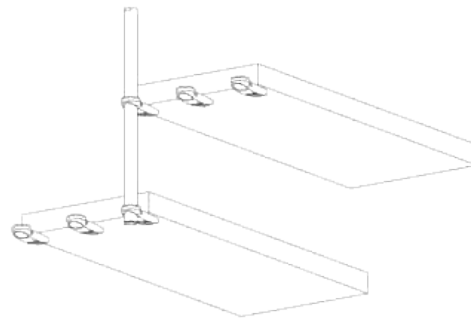

28

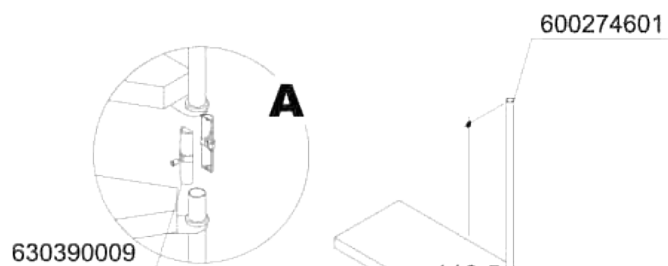
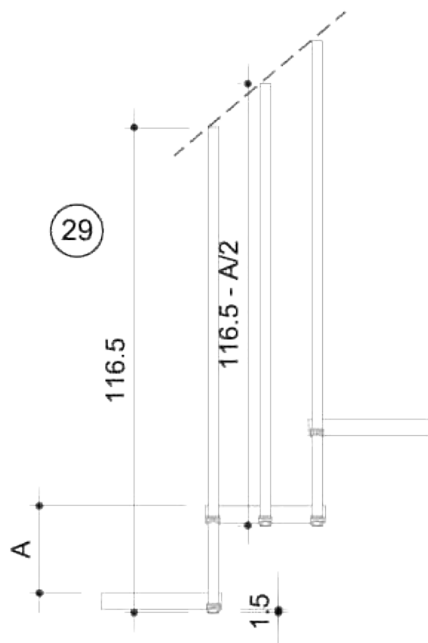

30

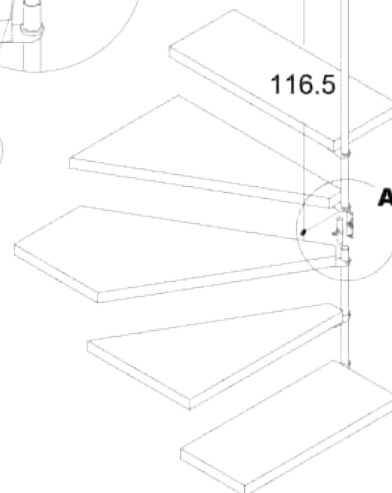

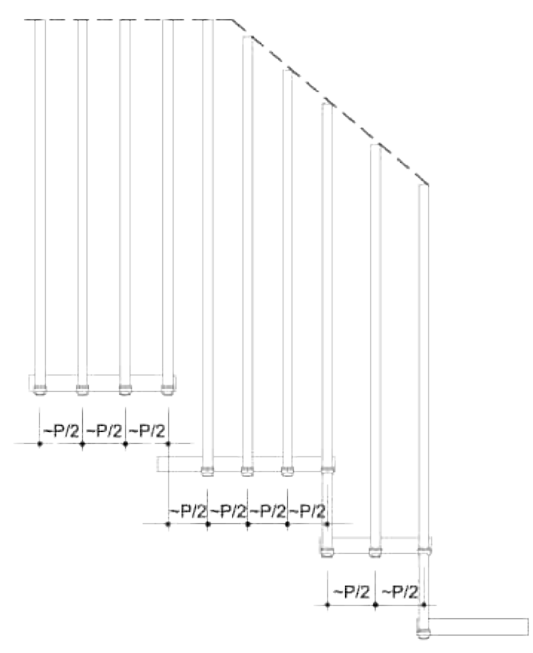
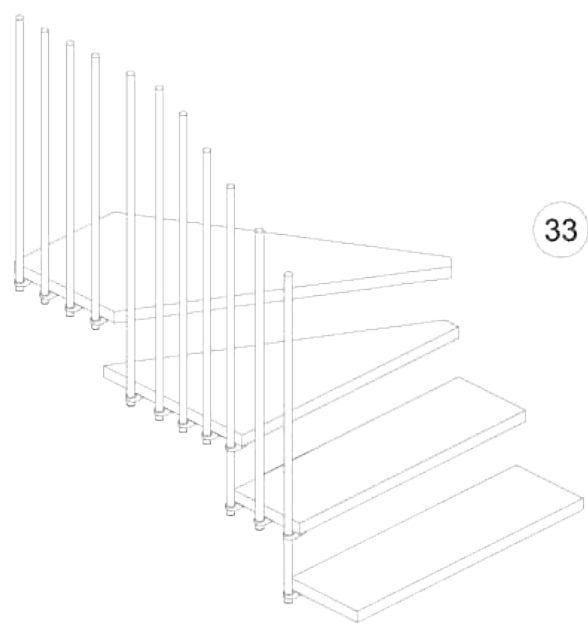
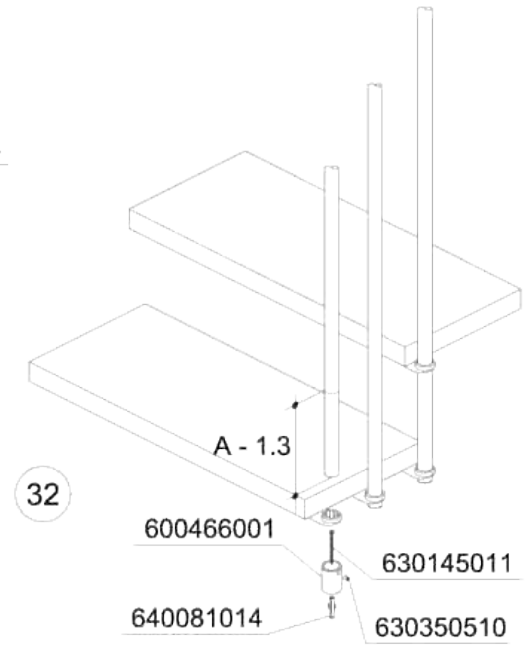
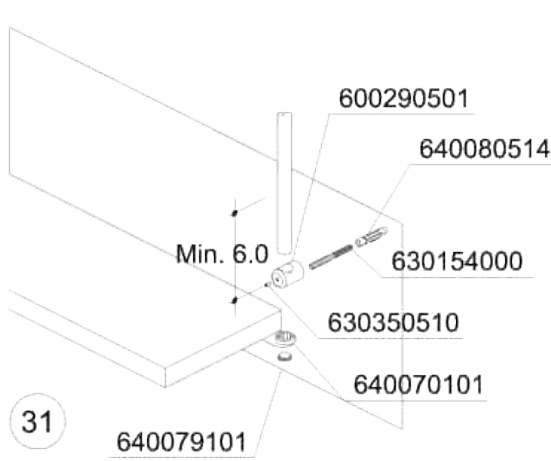

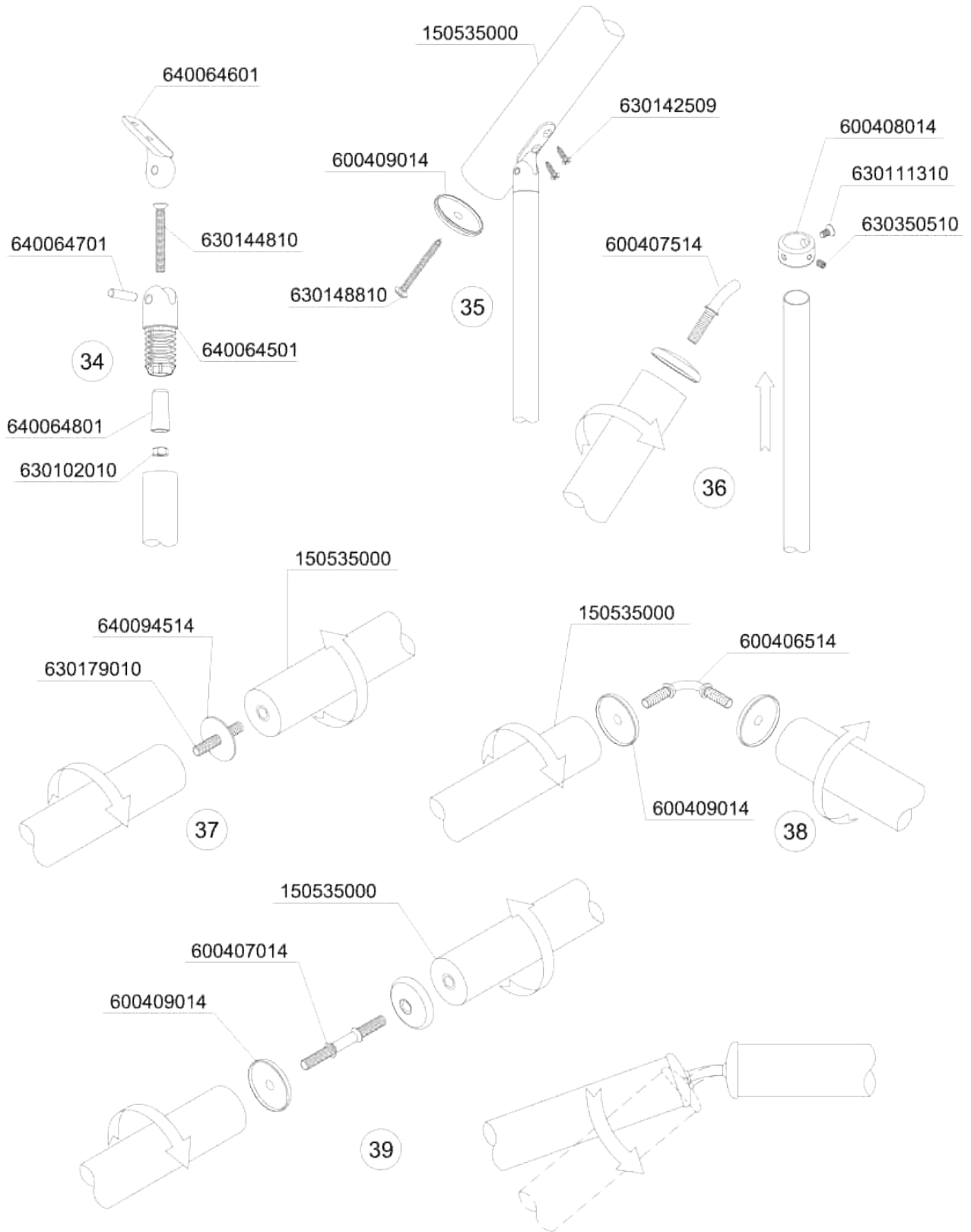

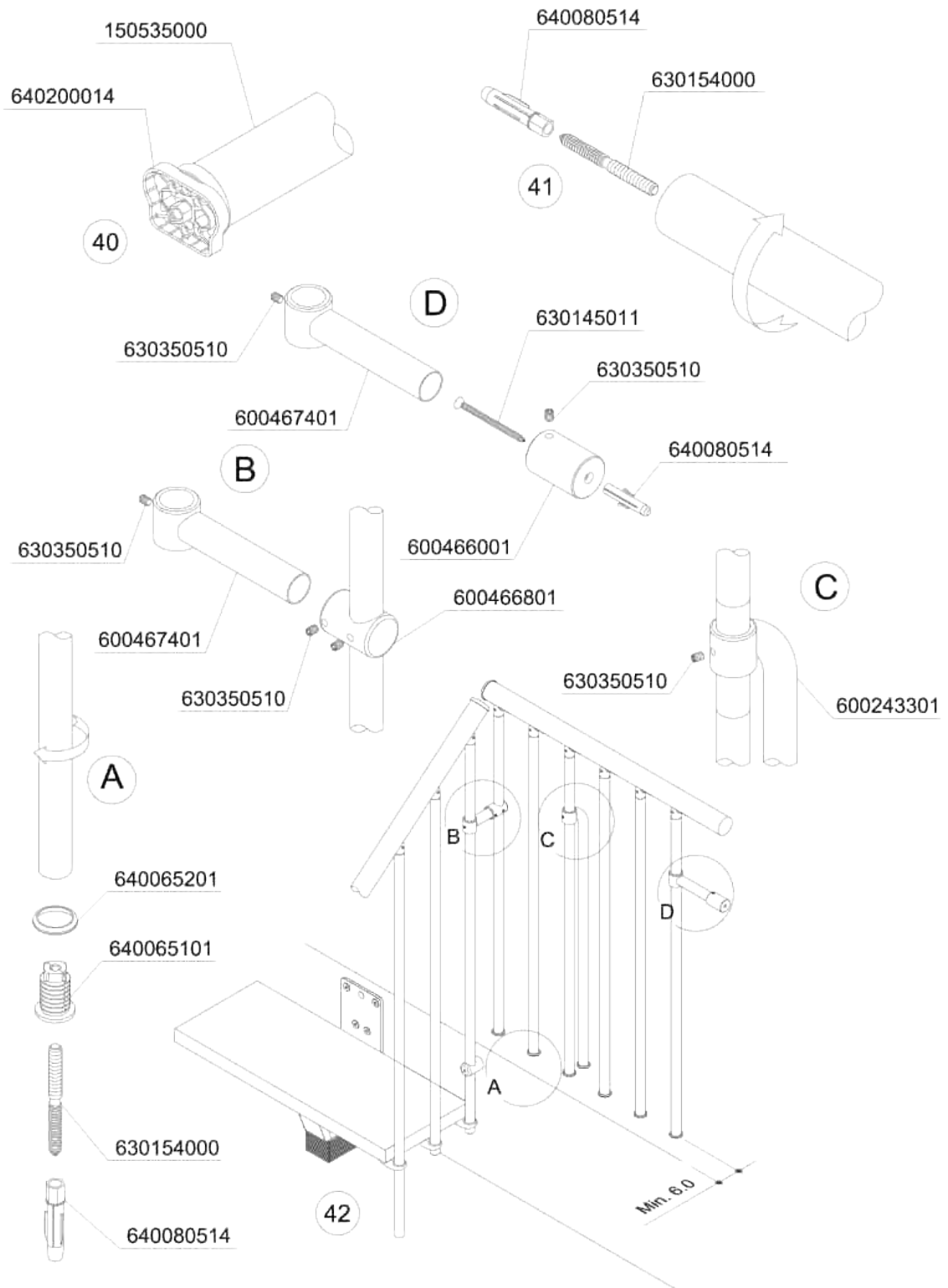

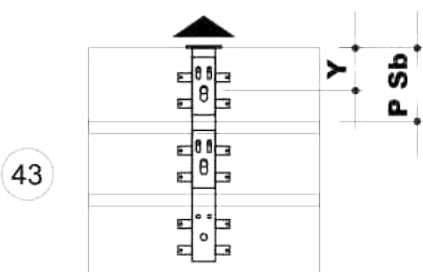

P	Co					
	P-Sb	Y	13.5	27	40	80
29.0	14.7			1		

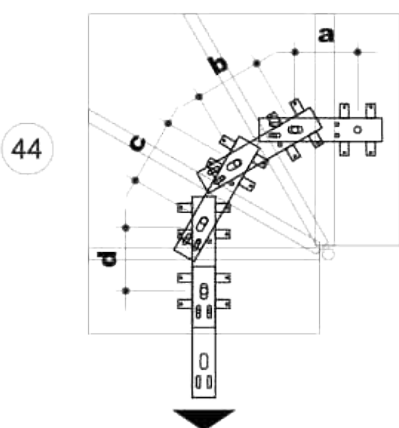

Lg	a	b	c	d
69.0	20.6	20.1	20.1	22.5
79.0	se $P < 23.6$, $a = 22.5$ se $P > 23.6$, $a = P - 1.1$	22.8	22.8	23.9
89.0	$P + 0.2$	25.5	25.5	25.2

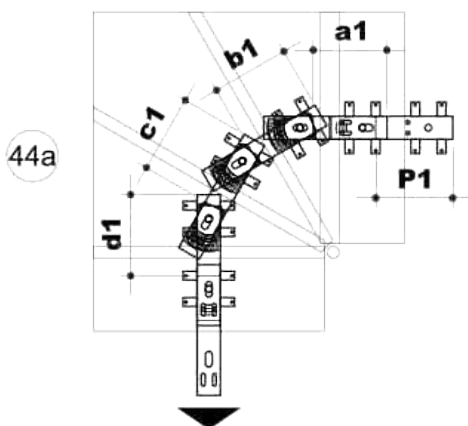

Lg	a1	b1	c1	d1	P1
69.0	22.4	21.9	21.9	24.3	$P + 1.8$
79.0	$a + 1.8$	24.6	24.6	25.7	$P + 1.8$
89.0	$a + 1.8$	27.3	27.3	27.0	$P + 1.8$

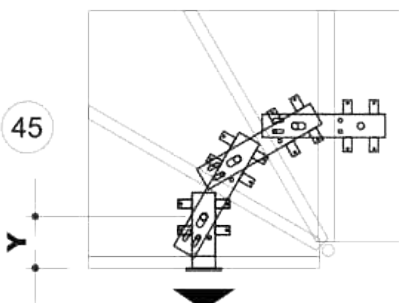

Lg	Y	Co			
		13.5	27	40	80
69.0	16.05	1		1	
79.0	17.4		1	1	
89.0	18.5				1

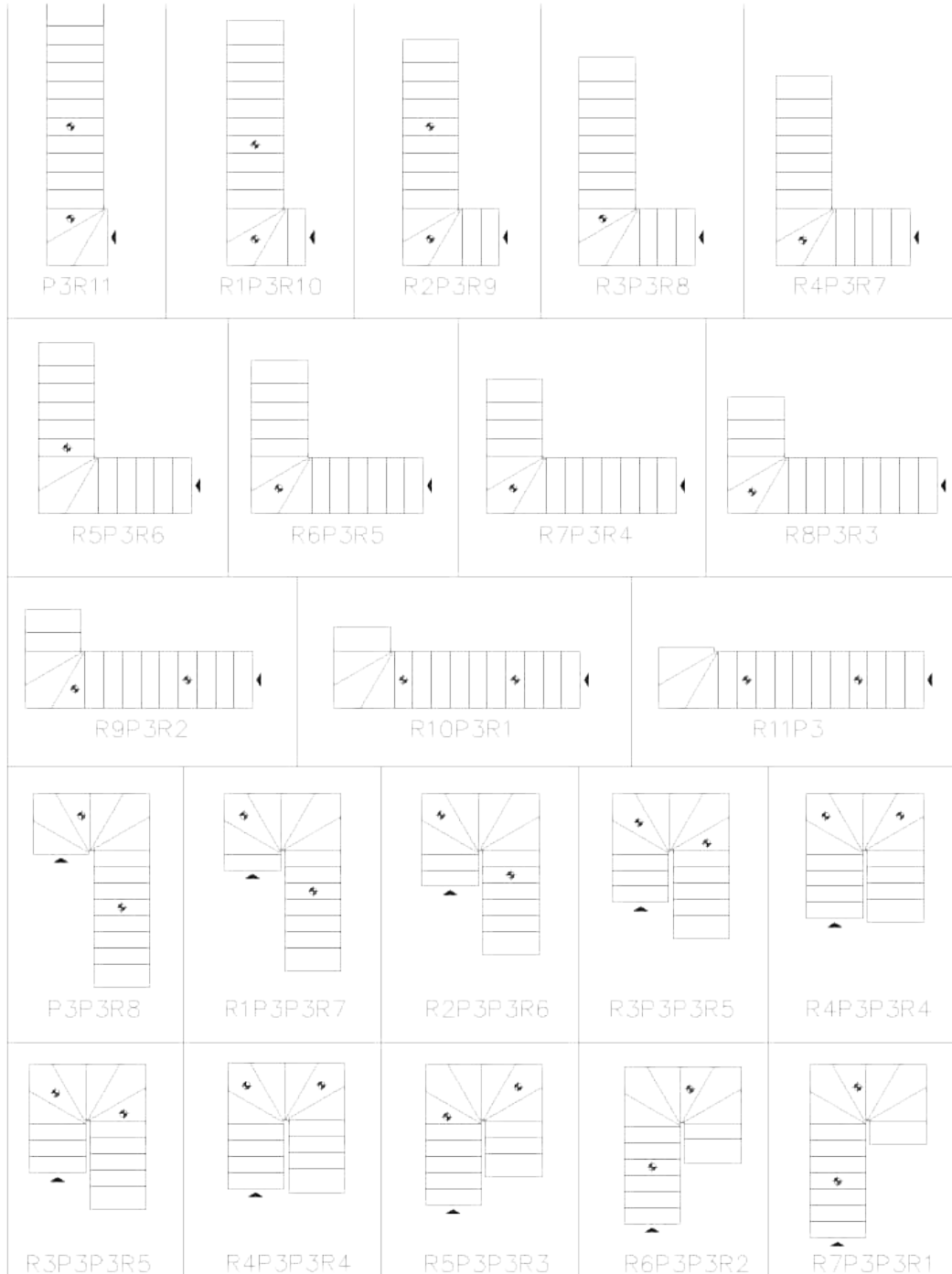

⚡ POSIZIONE ROMPIRATTA - SECTION BREAKER POSITION - POSITION LINCOIR - POSICIÓN ROMPESECCIÓN - POSITION STRECKEBRECHER

CONFIGURAZIONI TECH "L" 14 GRAD. - CONFIGURATIONS TECH "L" 14 STEPS -
CONFIGURATIONS TECH "L" 14 MARCHES - CONFIGURACIONES TECH "L" 14
PELDAÑOS - KONFIGURATIONEN TECH "L" 14 STUFEN

 R8P3P3	 P3R1P3R7	 R1P3R1P3R6	 R2P3R1P3R5	 R3P3R1P3R4
 R4P3R1P3R3	 R5P3R1P3R2	 R6P3R1P3R1	 R7P3R1P3	
 P3R2P3R6	 R1P3R2P3R5	 R2P3R2P3R4	 R3P3R2P3R3	
 R4P3R2P3R2	 R5P3R2P3R1	 R6P3R2P3	 P3R3P3R5	
 R1P3R3P3R4	 R2P3R3P3R3	 R3P3R3P3R2	 R4P3R3P3R1	

 POSIZIONE ROMPIRATTA - SECTION BREAKER POSITION - POSITION LINCOIR - POSICIÓN ROMPESECCIÓN -
POSITION STRECKEBRECHER

CONFIGURAZIONI TECH "L" 14 GRAD. - CONFIGURATIONS TECH "L" 14 STEPS -
CONFIGURATIONS TECH "L" 14 MARCHES - CONFIGURACIONES TECH "L" 14
PELDAÑOS - KONFIGURATIONEN TECH "L" 14 STUFEN

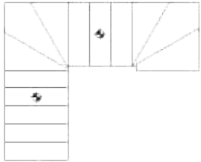
 R5P3R3P3	 P3R4P3R4	 R1P3R4P3R3	 R2P3R4P3R2
 R3P3R4P3R1	 R4P3R4P3	 P3R4P3R4	 R1P3R4P3R3
 R2P3R4P3R2	 R3P3R4P3R1	 R4P3R4P3	 P3R5P3R3
 R1P3R5P3R2	 R2P3R5P3R1	 R3P3R5P3	
 P3R6P3R2	 R1P3R6P3R1	 R2P3R6P3	
 P3R7P3R1	 R1P3R7P3	 P3R8P3	

 POSIZIONE ROMPIRATTA - SECTION BREAKER POSITION - POSITION LINCOIR - POSICIÓN ROMPESECCIÓN -
POSITION STRECKEBRECHER

CONFIGURAZIONI TECH "L" 12 GRAD. - CONFIGURATIONS TECH "L" 12 STEPS -
CONFIGURATIONS TECH "L" 12 MARCHES - CONFIGURACIONES TECH "L" 12
PELDAÑOS - KONFIGURATIONEN TECH "L" 12 STUFEN







































 POSIZIONE ROMPIRATTA - SECTION BREAKER POSITION - POSITION LINCOIR - POSICIÓN ROMPESECCIÓN -
POSITION STRECKEBRECHER



















CONFIGURAZIONI TECH "L" 12 GRAD. - CONFIGURATIONS TECH "L" 12 STEPS -
CONFIGURATIONS TECH "L" 12 MARCHES - CONFIGURACIONES TECH "L" 12
PELDAÑOS - KONFIGURATIONEN TECH "L" 12 STUFEN



















 P3R2P3R4	 R1P3R2P3R3	 R2P3R2P3R2	 R3P3R2P3R1
 R4P3R2P3	 P3R3P3R3	 R1P3R3P3R2	 R2P3R3P3R1
 R3P3R3P3	 P3R4P3R2	 R1P3R4P3R1	
 R2P3R4P3	 P3R5P3R1	 R1P3R5P3	
 P3R6P3			













 POSIZIONE ROMPIRATTA - SECTION BREAKER POSITION - POSITION LINCOIR - POSICIÓN ROMPESECCIÓN -
POSITION STRECKEBRECHER



















TECH 75	L 	U 	COD.	IMAGE 
	13	13	601670501	
	1	1	601671001	
	1	1	600673001	
	1	1	600674001	
	1	1	600675001	
	1	1	600674501	
	13	13	600675514	
	24	19	600269001	
	1	1	600407009	
	3	4	600408509	
	7	10	600409009	
	1	2	600407509	
	1	2	600408009	
	5	4	600467901	
	5	4	600470101	
	1	1	600466001	



















TECH 75	L 	U 	COD.	IMAGE
	1	1	600290501	
	24	24	600676010	
	54	54	600201200	
	1	1	600678001	
	1	1	600679501	
	2	2	600061609	
	11	8	111951012 111951016	
	2	4	111956012 111956016	
	1	2	111961012 111961016	
	1	1	151976512 151976516	
	5	4	150535012 150535016	
	221	221	640093601	
	48	48	640079901	
	6	6	640078701	
	27	27	640075601	
	30	24	640070101	



















TECH 75	L 	U 	COD.	IMAGE
	18	13	640079101	
	20	15	640064501	
	20	15	640064601	
	20	15	640064701	
	20	15	640064801	
	3	2	640094514	
	1	2	630111310	 M6 X 10
	3	4	630350510	 M6 X 8
	4	6	630148809	 7 X 70
	1	1	630145011	 6 X 50
	1	1	640081014	 D 8
	5	4	640082014	 D 14
	10	4	630148010	 6 X 30
	1	1	630154000	 10 X 100
	1	1	640080514	 12 X 60
	2	4	630394001	 D. 25



















TECH 75	L 	U 	COD.	IMAGE
	1	2	630353011	 M8 X 16
	11	11	630562010	 M22 X 150
	11	11	630103510	 M22
	2	2	630103210	 M12
	21	18	630330610	 24 X 13
	11	11	630330710	 39 X 23
	48	48	630145310	 6 X 60
	12	12	630071514	 D. 6
	19	16	630112110	 M12 X 120
	13	11	630180010	 M10 X 80
	10	10	630333010	 M10
	3	3	630180510	 M10 X 105
	11	11	630102909	 M10 X 18
	2	2	630135610	 M12 X 120
	20	15	630102010	 M6
	40	30	630142009	 5 X 20













TECH 75	L 	U 	COD.	IMAGE
	20	15	630144810	 M6 X 50
	30	24	630201009	 4 X 20
	30	24	630148509	 7 X 70
	30	24	630142509	 5 X 40
	3	2	630179010	 M10 X 60
	4	4	630107011	 M8
	1	1	630176610	 M8 X 140
	1	1	630112011	 M10 X 25
	1	1	630330010	 10 X 20
	1	1	650174500	



















TECH 85	L 	U 	COD.	IMAGE 
	13	13	601670001	
	1	1	601671001	
	1	1	600673001	
	1	1	600673501	
	1	1	600675001	
	1	1	600674501	
	13	13	600675514	
	24	19	600274601	
	1	1	600407009	
	3	4	600408509	
	7	10	600409009	
	1	2	600407509	
	1	2	600408009	
	1	1	600466001	
	5	4	600467901	
	5	4	600470101	



















TECH 85	L 	U 	COD.	IMAGE
	1	1	600290501	
	24	24	600676010	
	54	54	600201200	
	1	1	600678001	
	1	1	60679501	
	2	2	600061609	
	11	8	111952012 111952016	
	2	4	111957012 111957016	
	1	2	111962012 111962016	
	1	1	151977512 151977516	
	5	4	150535012 150535016	
	221	221	640093601	
	48	48	640079901	
	6	6	640078701	
	27	27	640075601	
	30	24	640070101	



















TECH 85	L 	U 	COD.	IMAGE
	18	13	640079101	
	3	2	640094514	
	20	15	640064501	
	20	15	640064601	
	20	15	640064701	
	20	15	640064801	
	1	2	630111310	 M6 X 10
	3	4	630350510	 M6 X 8
	4	6	630148809	 7 X 70
	1	1	630145011	 6 X 50
	1	1	640081014	 D 8
	5	4	640082014	 D 14
	10	4	630148010	 6 X 30
	1	1	630154000	 10 X 100
	1	1	640080514	 12 X 60
	2	4	630390009	 D 25



















TECH 85	L 	U 	COD.	IMAGE
	1	2	630353011	 M8 X 16
	11	11	630562010	 M22 X 150
	11	11	630103510	 M22
	2	2	630103210	 M12
	21	18	630330610	 24 X 13
	11	11	630330710	 39 X 23
	48	48	630145310	 6 X 60
	12	12	630071514	 D 6
	19	16	630112110	 M12 X 120
	13	11	630180010	 M10 X 80
	10	10	630333010	 M10
	3	3	630180510	 M10 X 105
	11	11	630102909	 M10 X 18
	2	2	630135610	 M12 X 120
	20	15	630102010	 M6
	40	30	630142009	 5 X 20













TECH 85	L 	U 	COD.	IMAGE
	20	15	630144810	 M6 X 50
	30	24	630201009	 4 X 20
	30	24	630113409	 6 X 40
	30	24	630142509	 5 X 40
	3	2	630179010	 M10 X 60
	4	4	630107011	 M8 X 16
	1	1	630176610	 M8 X 140
	1	1	630112011	 M10 X 25
	1	1	630330010	 10 X 20
	1	1	650174500	

TECH 95	L 	U 	COD.	IMAGE 
	13	13	601670001	
	1	1	601671001	
	1	1	600673001	
	1	1	600672501	
	1	1	600675001	
	1	1	600674501	
	13	13	600675514	
	24	19	600274601	
	1	1	600407009	
	3	4	600408509	
	7	10	600409009	
	1	2	600407509	
	1	2	600408009	
	1	1	600466001	
	5	4	600467901	
	5	4	600470101	

TECH 95	L 	U 	COD.	IMAGE
	1	1	600290501	
	24	24	600676010	
	54	54	600201200	
	1	1	600678001	
	1	1	60679501	
	2	2	600061609	
	11	8	111953012 111953016	
	2	4	111958012 111958016	
	1	2	111963012 111963016	
	1	1	151978512 151978516	
	5	4	150535012 150535016	
	221	221	640093601	
	48	48	640079901	
	6	6	640078701	
	27	27	640075601	
	30	24	640070101	

TECH 95	L 	U 	COD.	IMAGE
	18	13	640079101	
	3	2	640094514	
	20	15	640064501	
	20	15	640064601	
	20	15	640064701	
	20	15	640064801	
	1	2	630111310	 M6 X 10
	3	4	630350510	 M6 X 8
	4	6	630148809	 7 X 70
	1	1	630145011	 6 X 50
	1	1	640081014	 D 8
	5	4	640082014	 D 14
	10	4	630148010	 6 X 30
	1	1	630154000	 10X 100
	1	1	640080514	 12 X 60
	2	4	630390009	 D 25

TECH 95	L 	U 	COD.	IMAGE
	1	2	630353011	 M8 X 16
	11	11	630562010	 M22 X 150
	11	11	630103510	 M22
	2	2	630103210	 M12
	21	18	630330610	 24 X 13
	11	11	630330710	 39 X 23
	48	48	630145310	 6 X 60
	12	12	630071514	 D 6
	19	16	630112110	 M12 X 120
	13	11	630180010	 M10 X 80
	10	10	630333010	 M 10
	3	3	630180510	 M10 X 105
	11	11	630102909	 M10 X 18
	2	2	630135610	 M12 X 120
	20	15	630102010	 M6
	40	30	630142009	 5 X 20

TECH 95	L 	U 	COD.	IMAGE
	20	15	630144810	 M6 X 50
	30	24	630201009	 4 X 20
	30	24	630113409	 6 X 40
	30	24	630142509	 5 X 40
	3	2	630179010	 M10 X 60
	4	4	630107011	 M8
	1	1	630176610	 M8 X 140
	1	1	630112011	 M10 X 25
	1	1	630330010	 10 X 20
	1	1	650174500	

Types de fixation et matériaux

Dans kit modèle Tech, les chevilles mécaniques type Fisher TA-M10 ou équivalent sont fournies de série. Les chevilles fournies sont en acier zinc chromé avec trois secteurs écrouants et sont adaptés pour l'ancrage sur les matériaux de construction les plus courants. Toutefois, puisqu'il n'est pas possible de régler tout condition limite avec la même cheville, nous indiquons dans le tableau ci-dessous une liste de situations dans lesquelles l'efficacité de la fixation est maintenue en fonction du type de maçonnerie et la comparaison avec la solution technique alternative (ancrage chimique). Les situations mises en évidence avec le "rouge" (☒) sont considérés comme pas appropriées avec les chevilles fournies. Le bras latéral peut remplacer le support au sol rendant indifférent la charge utile de l'escalier que dans les cas où ils rencontrent les cas indiqués en "vert" (☑) de la table. Dans les configurations où il ya deux soutiens au sol seulement l'un des deux peut être remplacé.



Nota Bene La Società **RINTAL SpA** declina ogni responsabilità che pertanto resta a carico dell'utilizzatore finale, nei casi di utilizzo di fissaggi non ritenuti idonei all'ancoraggio sui materiali di cui è costituito il vano di montaggio.
Attention The Company **RINTAL SpA** disclaims any liability and the end user will be held the only responsible, in cases of use of fixings not considered suitable for the anchoring on the materials that make up the assembling well.
Attention Le Société **RINTAL Spa** décline toute responsabilité qui est assumée donc par l'utilisateur final, en cas d'utilisation de fixations considérées pas convenable pour l'ancrage dans matériaux qui font la cage de montage.
Atención La empresa **RINTAL SpA** declina toda responsabilidad que recae en el usuario final, en los casos de utilización de fijaciones que no se consideran adecuados por el anclaje a materiales que forman el hueco de montaje.
Achtung Das Unternehmen **RINTAL SpA** übernimmt keine Verantwortung, die daher in der Verantwortung des Endbenutzers bleibt, in Fällen des Einsatz von Befestigungen, die sich als nicht geeignet angesehen Verankerung an Material des Montage-Raums halten.

Matériaux de construction	Ancrage mécanique (de série)	Ancrage chimique (pas en dotation)
Béton C20/25 résistance à la compression 25 N/mm ²	✓	✓
BRIQUE PLEINE	✓	✓
PANNEAUX / STRUCTURES EN BOIS Placoplâtre, Panneaux de ciment, Panneaux de contreplaqué	✗ *	
PIERRE NATURELLE / ROCHE	☐	✓ **
BRIQUE PERFORÉE Brique avec perçages transversaux, Pierre percé calcifiée	✗	✓
GYPSE	✗ *	
BRIQUE EN PIERRE CALCAIRE	☐	✓
BÉTON LÉGER Béton cellulaire, Calcestruzzo cellulare, ciment spongieux	✗	✓
MÉTAL	**	

* à cause de la faible consistance du matériau, nous vous conseillons l'avis technique d'un professionnel pour une étude de faisabilité et pour une recherche des fixations optimales ** Pour l'ancrage à poutres en acier ou d'autres éléments métalliques, il est nécessaire d'utiliser une visserie avec filet métrique. En cas de doutes et perplexités, nous vous conseillons l'avis d'un professionnel pour l'évaluation du matériel de construction et le choix des fixations.

MONTAGE

TA-M con vite TE cl. 8.8

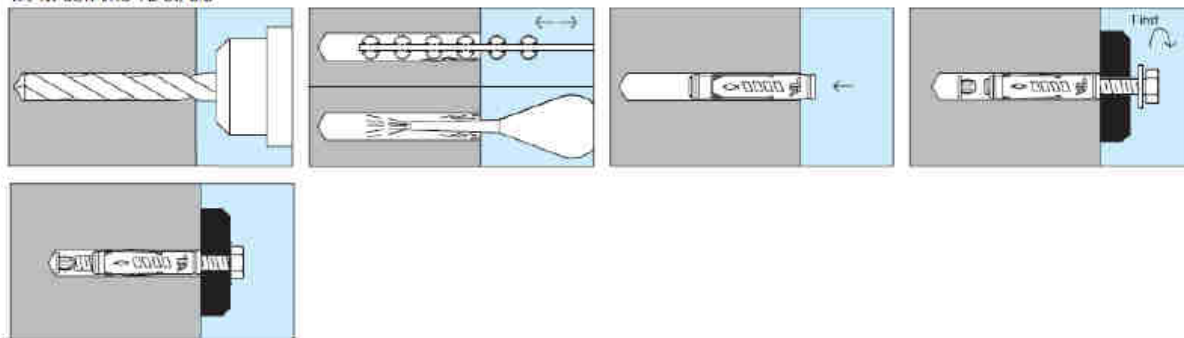

TA M-SK

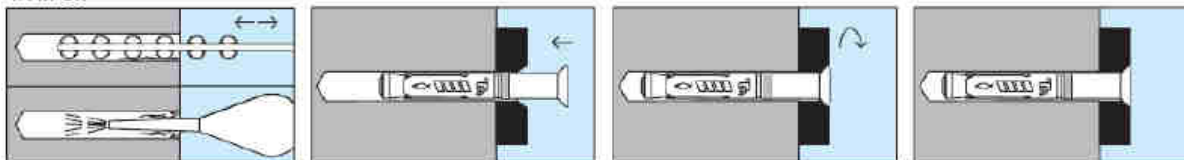

DONNEES TECHNIQUE



TA M



art.	descrizione	ov	Lt	øf	P	M	pz
90245	TA M6	M 6	49.5	10	65	5	50
90246	TA M8	M 8	56.5	12	70	12	50
90247	TA M10	M 10	69.0	15	90	20	25
90248	TA M12	M 12	85.5	18	115	35	25

$L_v = L_t + S$

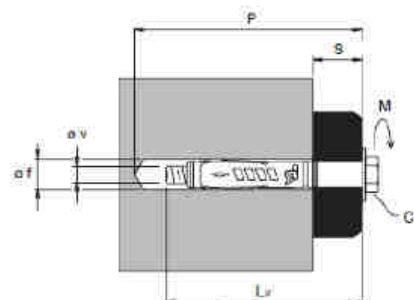

Lt= Longueur ancrage mm
 øf= Diamètre du foret en mm
 P= Profondeur minimale de trou en mm
 S= Épaisseur maximum fixable en mm
 øv= Diamètre vis en mm
 Lv= Longueur vis
 Ch= Clé
 M= Couple de serrage Nm
 Pz= Pièces par paquet